

Thrust Ball Bearings

Design

Thrust Ball Bearings are made as single -direction and double-direction bearings. Single-direction Thrust Ball Bearings can sustain an axial load in only one direction, whereas Double-direction Thrust Ball Bearings can sustain bi-directional thrust load.

Both types of Thrust Ball Bearings cannot sustain a radial load.

Both Thrust Ball Bearings are available with aligning housing washers for mating with a housing having an aligning surface radius. Aligning seat washers with an aligning surface radius are also available for ease of design and mounting against a flat housing shoulder.

The Bearings with a polyamide cage are indicated suffix G at bearing number on package surface.

Table 1. Bearing series

Type	Flat back-face type	Spherical back-face type	With aligning seat
Single-direction	511	—	—
	512	532	532U
	513	533	533U
	514	534	534U
	29	—	—
	39	—	—
	O (1)	—	—
	TAM(2)	—	—
	TG(2)	—	—
Double-direction	522	542	542U
	523	543	543U
	524	544	544U

Table 2

Bearing series	Bore diameter No.
511	28 ~
512, 522, 532, 542	26 ~
513, 523, 533, 543	22 ~
514, 524, 534, 544	17 ~

Notes: (1) Series O is inch-dimensioned.

(2) Series TAM, TG is extra-small and miniature.





Attention

- (1) Thrust Ball Bearings with flat housing washers do not permit any angular misalignment between shaft and housing, nor can they accommodate any error of angle between the support surfaces in the housing and on the shaft.
- (2) They are not suitable for high speed applications. Limiting speed are indicated in the dimension table.
- (3) The outside diameters of shaft washer and housing washer or center washer are the same, so clearance must be provided for the outside diameter of shaft washer or center washer by use of a step in the housing bore (See Fig.1). The outside diameter of the shaft washer or center washer of the bearings that are indicated in Table 2 are smaller than that of the housing washer, so no clearance step is required in the housing for the shaft (center) washer. See Fig.2.
- (4) Bearings with polyamide cage should be used less than 120°C.

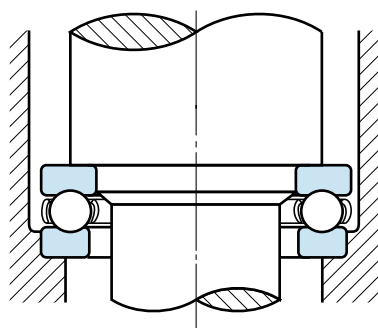

Single-direction

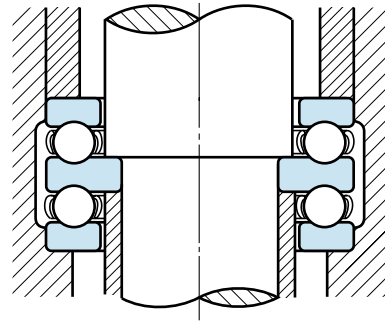
Fig 1

Double-direction

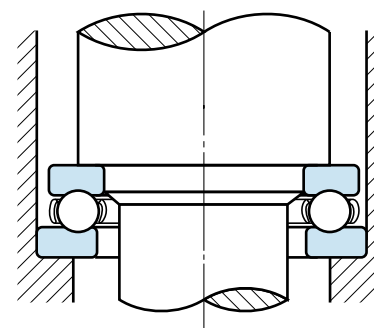

Single-direction

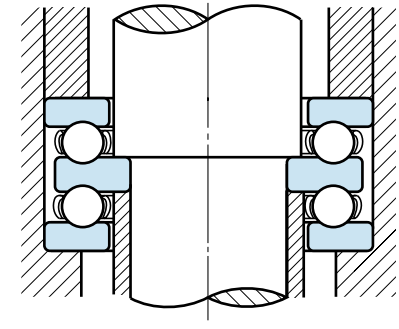
Fig 2

Double-direction



Cage

Standard fitting cages are shown in Table 3. If other cages are necessary, please contact NACHI.

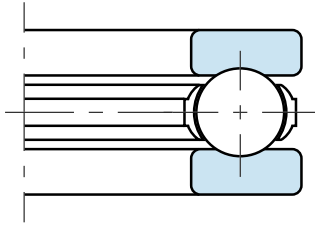

Fig 3. Polyamide

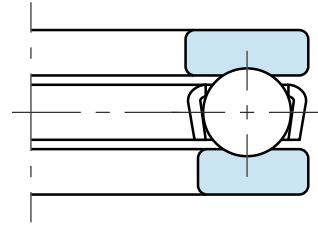

Fig 4. Pressed Steel

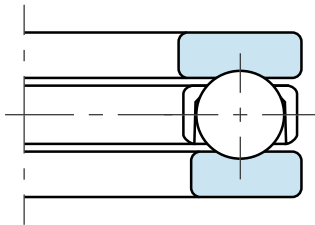

Fig 5. Machined

Table 3. Cage of Thrust Ball Bearings

Series	Diameter Number		
	Polyamide	Pressed Steel	Machined
511	00 ~ 07	08 ~ 52	56 ~ 72
512	01 ~ 07	00, 08 ~ 28	30 ~ 72
513	—	05 ~ 20	22 ~ 40
514	—	05 ~ 14	15 ~ 36
522	02 ~ 07	08 ~ 28	30 ~ 44
523	—	05 ~ 20	22 ~ 40
524	—	05 ~ 14	15 ~ 36
532	01 ~ 07	00, 08 ~ 28	30 ~ 72
533	—	05 ~ 20	22 ~ 40
534	—	05 ~ 14	15 ~ 36
542	02 ~ 07	08 ~ 28	30 ~ 44
543	—	05 ~ 20	22 ~ 24
544	—	05 ~ 14	15 ~ 20
29	—	00 ~ 22	23 ~ 28
39	—	05 ~ 24	—
0 —	—	3 ~ 30	32 ~ 48
TAM	—	3 ~ 8 ⁽¹⁾	—
TG	—	5 ~ 8 ⁽¹⁾	—

Remarks 1. Basic load rating of dimension table are indicated in using cage of table 3.

Notes⁽¹⁾ Indicate bore diameter not bore number.



Minimum axial load

When Thrust Ball Bearings are run at high speeds, the contact angle between the ball and the raceway in the radial plane is affected by the centrifugal force of the balls and the sliding movement between the balls and raceways are occurred. The sliding movement may cause damage as smearing. To prevent this damage, Thrust Ball Bearings must be subjected to a given load more than a minimum load from function (1) or (2).

Single-direction Thrust Ball Bearings can sustain only one direction axial load, so if bi-direction axial loads are present, Double-direction Thrust Ball Bearings must be used and preloaded by a load more than the minimum load.

In case of a vertical axis, shaft weight often exceeds the minimum load. In this case, the acting load may be decreased by the external axial load acting in the opposite direction.

$$F_{a \min} = K \cdot n^2 \quad \dots\dots\dots (1)$$

$$F_{a \min} = \frac{C_{oa}}{1000} \quad \dots\dots\dots (2)$$

Use the larger result of (1) or (2)

$F_{a \min}$ =Minimum axial load (N)

K =Minimum axial factor

see Table 4

n =Rotating speed(rpm)

C_{oa} =Basic static load rating (N)

Table 4. Minimum axial factor K ($\times 10^{-6}$)

Table 4. Minimum axial factor K ($\times 10^{-6}$)

Series Bore No.	511	512, 522	513, 523	514, 524
00	1.03	1.55	—	—
01	1.26	1.92	—	—
02	1.56	3.36	—	—
03	1.84	4.09	—	—
04	3.42	7.33	—	—
05	7.19	13.1	20.4	43.8
06	9.36	17.2	33.1	81.4
07	11.2	32.8	58.3	128
08	20.4	49.7	97.2	221
09	24.6	57.9	138	316
10	29.3	66.8	211	440
11	44.6	133	326	656
12	64.7	160	375	956
13	72.0	179	428	1240
14	82.8	200	596	1580
15	94.3	222	808	1800
16	103	245	907	2230
17	116	359	1240	2740
18	187	528	1390	4320
20	363	850	1850	4790
22	423	1010	2740	8220

Series Bore No.	511	512, 522	513, 523	514, 524
24	488	1130	4130	9980
26	648	1940	5140	16100
28	782	2150	6330	16900
30	886	2490	7140	25800
32	997	2880	9960	30000
34	1420	3940	11100	40100
36	1540	4330	15800	46330
38	2340	6290	23100	—
40	2520	6880	29700	—
44	3000	8130	—	—
48	4900	15900	—	—
52	5580	18400	—	—
56	9800	20400	—	—
60	14600	38000	—	—
64	16400	41800	—	—
68	18300	45700	—	—
72	20300	75600	—	—



Table 4. Minimum axial factor K ($\times 10^{-6}$)

(2/2)

Series Bore No.	29	39
00	1.55	—
01	1.92	—
02	2.64	—
03	3.30	—
04	3.82	—
04 1/2	6.41	—
05	7.51	14.2
06	9.72	28.9
07	20.1	52.3
08	25.1	81.0
09	31.6	140
10	46.1	209
11	54.4	284
12	60.7	350
13	86.0	426

Series Bore No.	29	39
14	99.5	556
15	114	704
16	152	927
17	172	1210
18	187	1580
19	286	2010
20	321	2090
21	346	2390
22	361	3220
23	350	3940
24	538	4500
25	498	—
26	—	—
27	—	—
28	794	—

Series Bore No.	O –
3	1.34
4	3.62
5	4.65
6	6.40
7	7.76
8	9.24
9	11.6
10	16.5
11	19.0
12	23.0
13	21.0
14	31.3
15	42.1
16	46.9
17	75.0

Series Bore No.	O –
18	82.8
19	110
20	121
21	132
22	176
23	204
24	223
26	350
28	395
30	431
32	580
36	1100
40	1730
44	2840
48	3690