



# 5. Accuracy of Bearings

---

## Introduction

---

### 5.1 Tolerance Values for Radial Bearings (Except Tapered Roller Bearings)

- Table 5.1.1 Tolerance Values of Inner Ring and of Outer Ring Width
- Table 5.1.2 Tolerance Values of Outer Ring

### 5.2 Tolerance Values for Metric Tapered Roller Bearings

- Table 5.2.1 Tolerance Values of Inner Ring
- Table 5.2.2 Tolerance Values of Outer Ring
- Table 5.2.3 Deviations of Single Ring Width, Bearing Width and Duplex/Stack Mounted Bearing Width

### 5.3 Tolerance Values for Thrust Ball Bearings

- Table 5.3.1 Tolerance Values of Shaft Washer Bore Diameter
- Table 5.3.2 Tolerance Values of Housing Washer Outside Diameter
- Table 5.3.3 Height Tolerances of Thrust Ball Bearings (with Flat Seat) and Center Washers (Class 0)

### 5.4 Tolerance Values of Spherical Roller Thrust Bearings (Class 0)

- Table 5.4.1 Tolerance Values of Inner Rings
- Table 5.4.2 Tolerance Values of Outer Rings

### 5.5 Tolerance Values of Tapered Roller Bearings - Inch Series

- Table 5.5.1 Tolerance of Inner Ring (Cone) Bore
- Table 5.5.2 Tolerance of Outer Ring (Cup) Outside Diameter
- Table 5.5.3 Tolerance of Bearing Width and Duplex/Stack Mounted Bearing Width
- Table 5.5.4 Radial Runout of Assembled Bearing Inner Ring and Outer Ring

### 5.6 Chamfer Dimensions

---

### 5.7 Tapered Bores

---

# 5. Accuracy of Rolling Contact Bearings

---

The tolerance of rolling contact bearings includes dimensional and running accuracy. According to JIS (1), tolerance is classified into 6 classes; class 0, 6, 6X, 5, 4 and 2 with accuracy ascending from class 0 to 2.

Applicable tolerance classes to individual bearing types and applicable standards are shown in the next page.

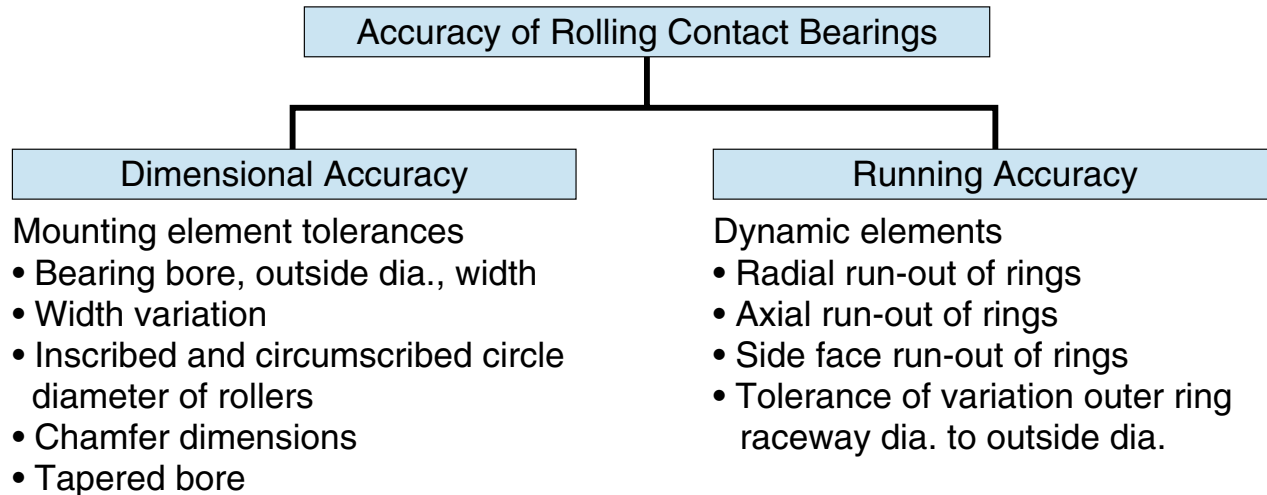

## Bearing types and tolerance classes



Bearing Type		Tolerance class					Related Standard	Reference Tables
Deep groove Ball Bearings		JIS 0	JIS 6	JIS 5	JIS 4	JIS 2	JIS B 1514	<b>5.1.1</b> <b>5.1.2</b>
Angular Contact Ball Bearings		JIS 0	JIS 6	JIS 5	JIS 4	JIS 2	JIS B 1514	<b>5.1.1</b> <b>5.1.2</b>
Self-aligning Ball Bearings		JIS 0	–	–	–	–		
Cylindrical Roller Bearings		JIS 0	JIS 6	JIS 5	JIS 4	JIS 2		
Spherical Roller (Radial) Bearings		JIS 0	–	–	–	–		
Tapered Roller Bearings	Metric Series	JIS 0 JIS 6X	JIS 6	JIS 5	JIS 4	–	JIS B 1514	<b>5.2.1</b> <b>5.2.2</b> <b>5.2.3</b>
	Inch Series	CLASS 4	CLASS 2	CLASS 3	CLASS 0	CLASS 00	ANSI / ABMA 19	<b>5.5.1</b> <b>5.5.2</b> <b>5.5.3</b> <b>5.5.4</b>
Thrust, Ball Bearings		JIS 0	JIS 6	JIS 5	JIS 4	–	JIS B 1514	<b>5.3.1</b> <b>5.3.2</b> <b>5.3.3</b>
Spherical Roller Thrust Bearings		JIS 0	–	–	–	–	JIS B 1514	<b>5.4.1</b> <b>5.4.2</b>

### Metric Radial Bearings (Except Tapered Roller Bearings) Class Comparison

Comparative Classes	ISO <sup>(2)</sup>		NORMAL CLASS	CLASS 6	CLASS 5	CLASS 4	CLASS 2	ISO 492 ISO 582	–
	DIN <sup>(3)</sup>		P0	P6	P5	P4	P2	DIN 620	–
	ANSI <sup>(4)</sup> / ABMA <sup>(5)</sup>	Ball Bearings	ABEC 1	ABEC 3	ABEC 5	ABEC 7	ABEC 9	ANSI / ABMA 20	–
		Roller Bearings	RBEC 1	RBEC 3	RBEC 5	–	–	ANSI / ABMA 20	–

(1) Japanese Industrial Standard (2) International Organization for Standardization (3) German Industrial Standards

(4) American National Standards Institute (5) American Bearing Manufacturers Association

Remarks: For tolerances of chamfer dimensions, see Table 5.6; for accuracy of tapered bore, see Table 5.7.

**Table 5.1.1 Tolerance Values of Inner Ring and of Outer Ring Width**

(1/4)

Unit:  $\mu\text{m}$

Bearing bore diameter Nominal d (mm)		Bearing with cylindrical bore													
		Single plane mean bore diameter deviation $\Delta d_{mp}$										Deviation of a single bore diameter (2) $\Delta d_s$			
		Class 0		Class 6		Class 5		Class 4		Class 2		Class 4 Diameter series 0,1,2,3,4		Class 2	
		High	Low	High	Low	High	Low	High	Low	High	Low	High	Low	High	Low
0.6 <sup>(1)</sup>	2.5	0	-8	0	-7	0	-5	0	-4	0	-2.5	0	-4	0	-2.5
2.5	10	0	-8	0	-7	0	-5	0	-4	0	-2.5	0	-4	0	-2.5
10	18	0	-8	0	-7	0	-5	0	-4	0	-2.5	0	-4	0	-2.5
18	30	0	-10	0	-8	0	-6	0	-5	0	-2.5	0	-5	0	-2.5
30	50	0	-12	0	-10	0	-8	0	-6	0	-2.5	0	-6	0	-2.5
50	80	0	-15	0	-12	0	-9	0	-7	0	-4	0	-7	0	-4
80	120	0	-20	0	-15	0	-10	0	-8	0	-5	0	-8	0	-5
120	150	0	-25	0	-18	0	-13	0	-10	0	-7	0	-10	0	-7
150	180	0	-25	0	-18	0	-13	0	-10	0	-7	0	-10	0	-7
180	250	0	-30	0	-22	0	-15	0	-12	0	-8	0	-12	0	-8
250	315	0	-35	0	-25	0	-18	-	-	-	-	-	-	-	-
315	400	0	-40	0	-30	0	-23	-	-	-	-	-	-	-	-
400	500	0	-45	0	-35	-	-	-	-	-	-	-	-	-	-
500	630	0	-50	0	-40	-	-	-	-	-	-	-	-	-	-
630	800	0	-75	-	-	-	-	-	-	-	-	-	-	-	-
800	1000	0	-100	-	-	-	-	-	-	-	-	-	-	-	-
1000	1250	0	-125	-	-	-	-	-	-	-	-	-	-	-	-
1250	1600	0	-160	-	-	-	-	-	-	-	-	-	-	-	-
1600	2000	0	-200	-	-	-	-	-	-	-	-	-	-	-	-

Notes: (1) This diameter is included in this group.

(2) Applies to bearings with cylindrical bore.

(3) Width deviation and variation of outer ring are the same with of inner ring. Outer ring width variation of classes 5, 4 and 2 are listed in Table 5.1.2.

(4) Applies to the rings of single bearings made for paired of stack mounting.

(5) Applies to radial ball bearings such as deep groove ball bearing, angular contact ball bearings.

Remarks: The high deviation of bearing cylindrical bore diameter specified in this table does not apply within a distance of  $1.2 \times r$  (max) from the ring face.



**Table 5.1.1 Tolerance Values of Inner Ring and of Outer Ring Width**

(2/4)

Unit:  $\mu\text{m}$

Bearing bore diameter Nominal d (mm)		Bearing with cylindrical bore																					
		Bore diameter variation in a single radial plane (2)										Main bore diameter variation (2)											
		$Vd_p$																					
		Class 0			Class 6			Class 5		Class 4		Class 2		Class 0		Class 6		Class 5		Class 4		Class 2	
		Diameter series			Diameter series			Diameter series		Diameter series		Class 2		Class 0		Class 6		Class 5		Class 4		Class 2	
Over	Incl.	7,8,9	0,1	2,3,4	7,8,9	0,1	2,3,4	7,8,9	0,1,2,3,4	7,8,9	0,1,2,3,4	Max	Max	Max	Max	Max	Max	Max	Max	Max	Max		
0.6 <sup>(1)</sup>	2.5	10	8	6	9	7	5	5	4	4	3	2.5	6	5	3	2	1.5						
2.5	10	10	8	6	9	7	5	5	4	4	3	2.5	6	5	3	2	1.5						
10	18	10	8	6	9	7	5	5	4	4	3	2.5	6	5	3	2	1.5						
18	30	13	10	8	10	8	6	6	5	5	4	2.5	8	6	3	2.5	1.5						
30	50	15	12	9	13	10	8	8	6	6	5	2.5	9	8	4	3	1.5						
50	80	19	19	11	15	15	9	9	7	7	5	4	11	9	5	3.5	2						
80	120	25	25	15	19	19	11	10	8	8	6	5	15	11	5	4	2.5						
120	150	31	31	19	23	23	14	13	10	10	8	7	19	14	7	5	3.5						
150	180	31	31	19	23	23	14	13	10	10	8	7	19	14	7	5	3.5						
180	250	38	38	23	28	28	17	15	12	12	9	8	23	17	8	6	4						
250	315	44	44	26	31	31	19	18	14	—	—	—	26	19	9	—	—						
315	400	50	50	30	38	38	23	23	18	—	—	—	30	23	12	—	—						
400	500	56	56	34	44	44	26	—	—	—	—	—	34	26	—	—	—						
500	630	63	63	38	50	50	30	—	—	—	—	—	38	30	—	—	—						
630	800	—	—	—	—	—	—	—	—	—	—	—	—	—	—	—	—						
800	1000	—	—	—	—	—	—	—	—	—	—	—	—	—	—	—	—						
1000	1250	—	—	—	—	—	—	—	—	—	—	—	—	—	—	—	—						
1250	1600	—	—	—	—	—	—	—	—	—	—	—	—	—	—	—	—						
1600	2000	—	—	—	—	—	—	—	—	—	—	—	—	—	—	—	—						

- Notes: (1) This diameter is included in this group.  
 (2) Applies to bearings with cylindrical bore.  
 (3) Width deviation and variation of outer ring are the same with of inner ring. Outer ring width variation of classes 5, 4 and 2 are listed in Table 5.1.2.  
 (4) Applies to the rings of single bearings made for paired of stack mounting.  
 (5) Applies to radial ball bearings such as deep groove ball bearing, angular contact ball bearings.

Remarks: The high deviation of bearing cylindrical bore diameter specified in this table does not apply within a distance of  $1.2 \times r$  (max) from the ring face.

**Table 5.1.1 Tolerance Values of Inner Ring and of Outer Ring Width**

(3/4)

Unit:  $\mu\text{m}$

Bearing bore diameter Nominal d (mm)		Deviation of a single inner ring width (or a single outer ring width) (2) $\Delta B_s$ (or $\Delta C_s$ )										Inner (or outer) ring width variation $V_{BS}$ (or $V_{CS}$ )				
		Single bearing						Paired or stack mounted bearing (4)				Inner ring (or outer ring) (3)		Inner ring		
		Class 0 Class 6		Class 5 Class 4		Class 2		Class 0 Class 6		Class 5 Class 4		Class 0	Class 6	Class 5	Class 4	Class 2
Over	Incl.	High	Low	High	Low	High	Low	High	Low	High	Low	Max	Max	Max	Max	Max
0.6 <sup>(1)</sup>	2.5	0	-40	0	-40	0	-40	-	-	0	-250	12	12	5	2.5	1.5
2.5	10	0	-120	0	-40	0	-40	0	-250	0	-250	15	15	5	2.5	1.5
10	18	0	-120	0	-80	0	-80	0	-250	0	-250	20	20	5	2.5	1.5
18	30	0	-120	0	-120	0	-120	0	-250	0	-250	20	20	5	2.5	1.5
30	50	0	-120	0	-120	0	-120	0	-250	0	-250	20	20	5	3	1.5
50	80	0	-150	0	-150	0	-150	0	-380	0	-250	25	25	6	4	1.5
80	120	0	-200	0	-200	0	-200	0	-380	0	-380	25	25	7	4	2.5
120	150	0	-250	0	-250	0	-250	0	-500	0	-380	30	30	8	5	2.5
150	180	0	-250	0	-250	0	-250	0	-500	0	-380	30	30	8	5	4
180	250	0	-300	0	-300	0	-300	0	-500	0	-500	30	30	10	6	5
250	315	0	-350	0	-350	-	-	0	-500	0	-500	35	35	13	-	-
315	400	0	-400	0	-400	-	-	0	-630	0	-630	40	40	15	-	-
400	500	0	-450	-	-	-	-	-	-	-	-	50	45	-	-	-
500	630	0	-500	-	-	-	-	-	-	-	-	60	50	-	-	-
630	800	0	-750	-	-	-	-	-	-	-	-	70	-	-	-	-
800	1000	0	-1000	-	-	-	-	-	-	-	-	80	-	-	-	-
1000	1250	0	-1250	-	-	-	-	-	-	-	-	100	-	-	-	-
1250	1600	0	-1600	-	-	-	-	-	-	-	-	120	-	-	-	-
1600	2000	0	-2000	-	-	-	-	-	-	-	-	140	-	-	-	-

Notes: (1) This diameter is included in this group.

(2) Applies to bearings with cylindrical bore.

(3) Width deviation and variation of outer ring are the same with of inner ring. Outer ring width variation of classes 5, 4 and 2 are listed in Table 5.1.2.

(4) Applies to the rings of single bearings made for paired of stack mounting.

(5) Applies to radial ball bearings such as deep groove ball bearing, angular contact ball bearings.

Remarks: The high deviation of bearing cylindrical bore diameter specified in this table does not apply within a distance of  $1.2 \times r$  (max) from the ring face.

**Table 5.1.1 Tolerance Values of Inner Ring and of Outer Ring Width**

(4/4)

Unit:  $\mu\text{m}$

Bearing bore diameter Nominal d (mm)		Radial runout of assembled bearing inner ring $K_{ia}$					Inner ring reference face runout with bore $S_d$			Assembled bearing inner ring face runout with raceway $S_{ia}$ (5)		
		Class 0	Class 6	Class 5	Class 4	Class 2	Class 5	Class 4	Class 2	Class 5	Class 4	Class 2
Over	Incl.	Max	Max	Max	Max	Max	Max	Max	Max	Max	Max	Max
0.6 <sup>(1)</sup>	2.5	10	5	4	2.5	1.5	7	3	1.5	7	3	1.5
2.5	10	10	6	4	2.5	1.5	7	3	1.5	7	3	1.5
10	18	10	7	4	2.5	1.5	7	3	1.5	7	3	1.5
18	30	13	8	4	3	2.5	8	4	1.5	8	4	2.5
30	50	15	10	5	4	2.5	8	4	1.5	8	4	2.5
50	80	20	10	5	4	2.5	8	5	1.5	8	5	2.5
80	120	25	13	6	5	2.5	9	5	2.5	9	5	2.5
120	150	30	18	8	6	2.5	10	6	2.5	10	7	2.5
150	180	30	18	8	6	5	10	6	4	10	7	5
180	250	40	20	10	8	5	11	7	5	13	8	5
250	315	50	25	13	—	—	13	—	—	15	—	—
315	400	60	30	15	—	—	15	—	—	20	—	—
400	500	65	35	—	—	—	—	—	—	—	—	—
500	630	70	40	—	—	—	—	—	—	—	—	—
630	800	80	—	—	—	—	—	—	—	—	—	—
800	1000	90	—	—	—	—	—	—	—	—	—	—
1000	1250	100	—	—	—	—	—	—	—	—	—	—
1250	1600	120	—	—	—	—	—	—	—	—	—	—
1600	2000	140	—	—	—	—	—	—	—	—	—	—

Notes: (1) This diameter is included in this group.

(2) Applies to bearings with cylindrical bore.

(3) Width deviation and variation of outer ring are the same with of inner ring. Outer ring width variation of classes 5, 4 and 2 are listed in Table 5.1.2.

(4) Applies to the rings of single bearings made for paired of stack mounting.

(5) Applies to radial ball bearings such as deep groove ball bearing, angular contact ball bearings.

Remarks: The high deviation of bearing cylindrical bore diameter specified in this table does not apply within a distance of  $1.2 \times r$  (max) from the ring face.

**Table 5.1.2 Tolerance Values of Outer Ring**

**(1/4)**

Unit:  $\mu\text{m}$

Bearing outside diameter Nominal D (mm)		Bearing outside diameter													
		Single plane mean outside diameter deviation $\Delta D_{mp}$										Deviation of a single outside diameter $\Delta D_s$			
		Class 0		Class 6		Class 5		Class 4		Class 2		Class 4		Class 2	
		Diameter series 0,1,2,3,4													
Over	Incl.	High	Low	High	Low	High	Low	High	Low	High	Low	High	Low	High	Low
2.5 <sup>(1)</sup>	6	0	-8	0	-7	0	-5	0	-4	0	-2.5	0	-4	0	-2.5
6	18	0	-8	0	-7	0	-5	0	-4	0	-2.5	0	-4	0	-2.5
18	30	0	-9	0	-8	0	-6	0	-5	0	-4	0	-5	0	-4
30	50	0	-11	0	-9	0	-7	0	-6	0	-4	0	-6	0	-4
50	80	0	-13	0	-11	0	-9	0	-7	0	-4	0	-7	0	-4
80	120	0	-15	0	-13	0	-10	0	-8	0	-5	0	-8	0	-5
120	150	0	-18	0	-15	0	-11	0	-9	0	-5	0	-9	0	-5
150	180	0	-25	0	-18	0	-13	0	-10	0	-7	0	-10	0	-7
180	250	0	-30	0	-20	0	-15	0	-11	0	-8	0	-11	0	-8
250	315	0	-35	0	-25	0	-18	0	-13	0	-8	0	-13	0	-8
315	400	0	-40	0	-28	0	-20	0	-15	0	-10	0	-15	0	-10
400	500	0	-45	0	-33	0	-23	-	-	-	-	-	-	-	-
500	630	0	-50	0	-38	0	-28	-	-	-	-	-	-	-	-
630	800	0	-75	0	-45	0	-35	-	-	-	-	-	-	-	-
800	1000	0	-100	0	-60	-	-	-	-	-	-	-	-	-	-
1000	1250	0	-125	-	-	-	-	-	-	-	-	-	-	-	-
1250	1600	0	-160	-	-	-	-	-	-	-	-	-	-	-	-
1600	2000	0	-200	-	-	-	-	-	-	-	-	-	-	-	-
2000	2500	0	-250	-	-	-	-	-	-	-	-	-	-	-	-

- Notes: (1) This diameter is included in this group.  
 (2) Applies before mounting and after removal of internal or external snap ring.  
 (3) Applies to radial ball bearings such as deep groove ball bearings, angular contact ball bearings.  
 (4) Outer ring width variation of class 0 and 6 are listed in Table 5.1.1.  
 (5) Applies to radial ball bearings such as deep groove ball bearing, angular contact ball bearings.

Remarks: The high deviation of bearing cylindrical bore diameter specified in this table does not apply within a distance of  $1.2 \times r$  (max) from the ring face.



**Table 5.1.2 Tolerance Values of Outer Ring**

(2/4)

Unit:  $\mu\text{m}$

Bearing outside diameter Nominal D (mm)		Bearing outside diameter												
		Outside diameter variation in a single radial plane (2)												
		$V_{Dp}$												
		Class 0				Class 6				Class 5		Class 4		Class 2
		Open bearing		Seal · shield bearing		Open bearing		Seal · shield bearing		Open bearing	Open bearing	Open bearing		
Diameter series		Diameter series		Diameter series		Diameter series		Diameter series	Diameter series	Diameter series		Diameter series	Open bearing	
7,8,9	0,1	2,3,4	2,3,4	7,8,9	0,1	2,3,4	0,1,2,3,4	7,8,9	0,1,2,3,4	7,8,9	0,1,2,3,4	7,8,9	0,1,2,3,4	Open bearing
Over	Incl.	Max	Max	Max	Max	Max	Max	Max	Max	Max	Max	Max	Max	Max
2.5 <sup>(1)</sup>	6	10	8	6	10	9	7	5	9	5	4	4	3	2.5
6	18	10	8	6	10	9	7	5	9	5	4	4	3	2.5
18	30	12	9	7	12	10	8	6	10	6	5	5	4	4
30	50	14	11	8	16	11	9	7	13	7	5	6	5	4
50	80	16	13	10	20	14	11	8	16	9	7	7	5	4
80	120	19	19	11	26	16	16	10	20	10	8	8	6	5
120	150	23	23	14	30	19	19	11	25	11	8	9	7	5
150	180	31	31	19	38	23	23	14	30	13	10	10	8	7
180	250	38	38	23	—	25	25	15	—	15	11	11	8	8
250	315	44	44	26	—	31	31	19	—	18	14	13	10	8
315	400	50	50	30	—	35	35	21	—	20	15	15	11	10
400	500	56	56	34	—	41	41	25	—	23	17	—	—	—
500	630	63	63	38	—	48	48	29	—	28	21	—	—	—
630	800	94	94	55	—	56	56	34	—	35	26	—	—	—
800	1000	125	125	75	—	75	75	45	—	—	—	—	—	—
1000	1250	—	—	—	—	—	—	—	—	—	—	—	—	—
1250	1600	—	—	—	—	—	—	—	—	—	—	—	—	—
1600	2000	—	—	—	—	—	—	—	—	—	—	—	—	—
2000	2500	—	—	—	—	—	—	—	—	—	—	—	—	—

- Notes: (1) This diameter is included in this group.  
 (2) Applies before mounting and after removal of internal or external snap ring.  
 (3) Applies to radial ball bearings such as deep groove ball bearings, angular contact ball bearings.  
 (4) Outer ring width variation of class 0 and 6 are listed in Table 5.1.1.  
 (5) Applies to radial ball bearings such as deep groove ball bearing, angular contact ball bearings.

Remarks: The high deviation of bearing cylindrical bore diameter specified in this table does not apply within a distance of  $1.2 \times r$  (max) from the ring face.

**Table 5.1.2 Tolerance Values of Outer Ring**

(3/4)

Unit:  $\mu\text{m}$

Bearing outside diameter Nominal D (mm)		Bearing outside diameter					Radial runout of assembled bearing outer ring					Variation of bearing outside surface generatrix inclination with outer ring reference face		
		Mean outside diameter variation (2)					Class $K_{ea}$					Class $S_D$		
		Class 0	Class 6	Class 5	Class 4	Class 2	Class 0	Class 6	Class 5	Class 4	Class 2	Class 5	Class 4	Class 2
Over	Incl.	Max	Max	Max	Max	Max	Max	Max	Max	Max	Max	Max	Max	
2.5 <sup>(1)</sup>	6	6	5	3	2	1.5	15	8	5	3	1.5	8	4	1.5
6	18	6	5	3	2	1.5	15	8	5	3	1.5	8	4	1.5
18	30	7	6	3	2.5	2	15	9	6	4	2.5	8	4	1.5
30	50	8	7	4	3	2	20	10	7	5	2.5	8	4	1.5
50	80	10	8	5	3.5	2	25	13	8	5	4	8	4	1.5
80	120	11	10	5	4	2.5	35	18	10	6	5	9	5	2.5
120	150	14	11	6	5	2.5	40	20	11	7	5	10	5	2.5
150	180	19	14	7	5	3.5	45	23	13	8	5	10	5	2.5
180	250	23	15	8	6	4	50	25	15	10	7	11	7	4
250	315	26	19	9	7	4	60	30	18	11	7	13	8	5
315	400	30	21	10	8	5	70	35	20	13	8	13	10	7
400	500	34	25	12	—	—	80	40	23	—	—	15	—	—
500	630	38	29	14	—	—	100	50	25	—	—	18	—	—
630	800	55	34	18	—	—	120	60	30	—	—	20	—	—
800	1000	75	45	—	—	—	140	75	—	—	—	—	—	—
1000	1250	—	—	—	—	—	160	—	—	—	—	—	—	—
1250	1600	—	—	—	—	—	190	—	—	—	—	—	—	—
1600	2000	—	—	—	—	—	220	—	—	—	—	—	—	—
2000	2500	—	—	—	—	—	250	—	—	—	—	—	—	—

Notes: (1) This diameter is included in this group.

(2) Applies before mounting and after removal of internal or external snap ring.

(3) Applies to radial ball bearings such as deep groove ball bearings, angular contact ball bearings.

(4) Outer ring width variation of class 0 and 6 are listed in Table 5.1.1.

(5) Applies to radial ball bearings such as deep groove ball bearing, angular contact ball bearings.

Remarks: The high deviation of bearing cylindrical bore diameter specified in this table does not apply within a distance of  $1.2 \times r$  (max) from the ring face.

**Table 5.1.2 Tolerance Values of Outer Ring****(4/4)**

Bearing outside diameter Nominal D (mm)		Assembled bearing outer ring face runout with raceway $S_{ea}$ (3)			Outer ring width variation $V_{Cs}$ (4)		
		Class 5	Class 4	Class 2	Class 5	Class 4	Class 2
Over	Incl.	Max	Max	Max	Max	Max	Max
2.5 <sup>(1)</sup>	6	8	5	1.5	5	2.5	1.5
6	18	8	5	1.5	5	2.5	1.5
18	30	8	5	2.5	5	2.5	1.5
30	50	8	5	2.5	5	2.5	1.5
50	80	10	5	4	6	3	1.5
80	120	11	6	5	8	4	2.5
120	150	13	7	5	8	5	2.5
150	180	14	8	5	8	5	2.5
180	250	15	10	7	10	7	4
250	315	18	10	7	11	7	5
315	400	20	13	8	13	8	7
400	500	23	—	—	15	—	—
500	630	25	—	—	18	—	—
630	800	30	—	—	20	—	—
800	1000	—	—	—	—	—	—
1000	1250	—	—	—	—	—	—
1250	1600	—	—	—	—	—	—
1600	2000	—	—	—	—	—	—
2000	2500	—	—	—	—	—	—

Notes: (1) This diameter is included in this group.

(2) Applies before mounting and after removal of internal or external snap ring.

(3) Applies to radial ball bearings such as deep groove ball bearings, angular contact ball bearings.

(4) Outer ring width variation of class 0 and 6 are listed in Table 5.1.1.

(5) Applies to radial ball bearings such as deep groove ball bearing, angular contact ball bearings.

Remarks: The high deviation of bearing cylindrical bore diameter specified in this table does not apply within a distance of  $1.2 \times r$  (max) from the ring face.

**Table 5.2.1 Tolerance Values of Inner Ring**

(1/2)

Unit:  $\mu\text{m}$

Bearing bore diameter Nominal d (mm)		Bearing bore diameter											
		Single plane mean bore diameter $\Delta d_{mp}$				Deviation of a single bore diameter $\Delta d_s$				Bore diameter variation in a single radial plane $Vd_p$			
		Class 0 Class 6X		Class 6 Class 5		Class 4		Class 4		Class 0 Class 6X	Class 6	Class 5	Class 4
Over	Incl.	High	Low	High	Low	High	Low	High	Low	Max	Max	Max	Max
10	18	0	-12	0	-7	0	-5	0	-5	12	7	5	4
18	30	0	-12	0	-8	0	-6	0	-6	12	8	6	5
30	50	0	-12	0	-10	0	-8	0	-8	12	10	8	6
50	80	0	-15	0	-12	0	-9	0	-9	15	12	9	7
80	120	0	-20	0	-15	0	-10	0	-10	20	15	11	8
120	180	0	-25	0	-18	0	-13	0	-13	25	18	14	10
180	250	0	-30	0	-22	0	-15	0	-15	30	22	17	11
250	315	0	-35	-	-	-	-	-	-	35	-	-	-
315	400	0	-40	-	-	-	-	-	-	40	-	-	-
400	500	0	-45	-	-	-	-	-	-	-	-	-	-
500	630	0	-50	-	-	-	-	-	-	-	-	-	-
630	800	0	-75	-	-	-	-	-	-	-	-	-	-

Remarks:

1. The high deviation of bearing bore diameter specified in this table does not apply within a distance of  $1.2 \times r$  (max) from the ring face.
2. Some of these tolerances conform with the NACHI Standard.

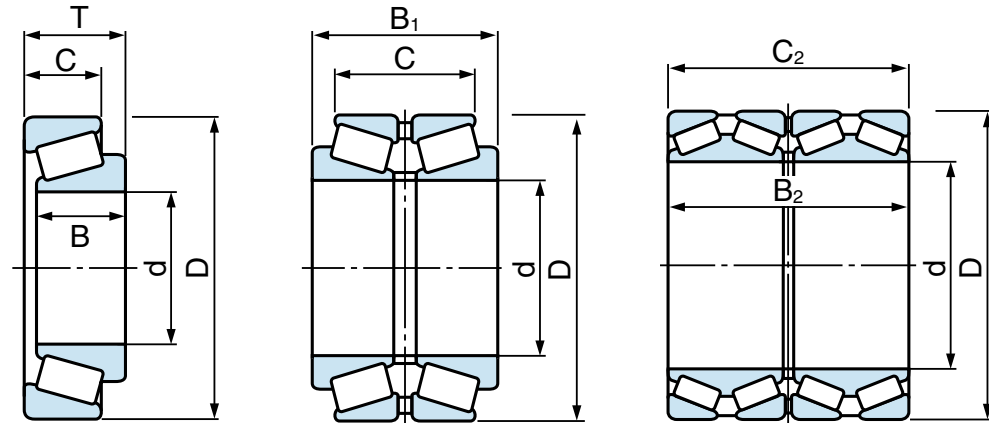

**Table 5.2.1 Tolerance Values of Inner Ring (2/2)**

Unit:  $\mu\text{m}$

Bearing bore diameter Nominal d (mm)		Bearing bore diameter Mean bore diameter variation $Vd_{mp}$				Radial runout of assembled bearing inner ring $K_{ia}$				Inner ring reference face runout with bore $S_d$		Assembled bearing inner ring face runout with raceway $S_{ia}$
		Class 0 Class 6X	Class 6	Class 5	Class 4	Class 0 Class 6X	Class 6	Class 5	Class 4	Class 5	Class 4	Class 4
Over	Incl.	Max	Max	Max	Max	Max	Max	Max	Max	Max	Max	Max
10	18	9	5	5	4	15	7	5	3	7	3	3
18	30	9	6	5	4	18	8	5	3	8	4	4
30	50	9	8	5	5	20	10	6	4	8	4	4
50	80	11	9	6	5	25	10	7	4	8	5	4
80	120	15	11	8	5	30	13	8	5	9	5	5
120	180	19	14	9	7	35	18	11	6	10	6	7
180	250	23	16	11	8	50	20	13	8	11	7	8
250	315	26	—	—	—	60	—	—	—	—	—	—
315	400	30	—	—	—	70	—	—	—	—	—	—
400	500	—	—	—	—	70	—	—	—	—	—	—
500	630	—	—	—	—	85	—	—	—	—	—	—
630	800	—	—	—	—	100	—	—	—	—	—	—

Remarks:

1. The high deviation of bearing bore diameter specified in this table does not apply within a distance of  $1.2 \times r$  (max) from the ring face.
2. Some of these tolerances conform with the NACHI Standard.

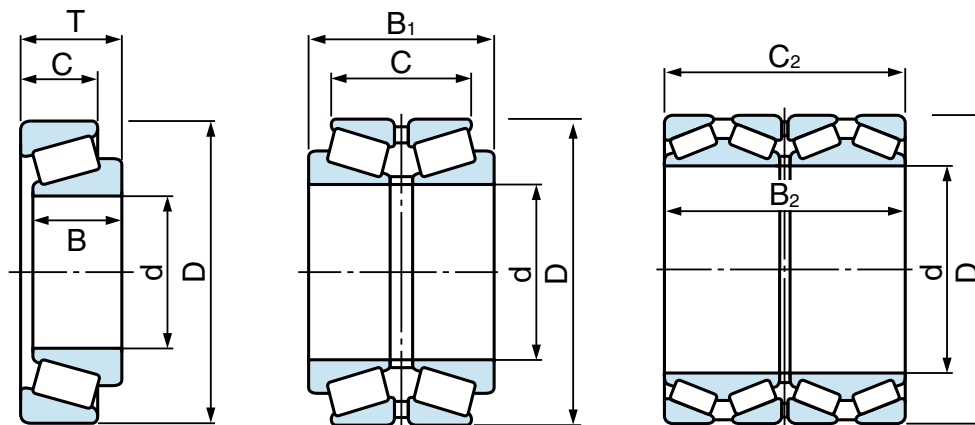

**Table 5.2.2 Tolerance Values of Outer Ring**

(1/2)

Unit:  $\mu\text{m}$

Bearing outside diameter Nominal D (mm)		Bearing outside diameter											
		Single plane mean outside diameter $\Delta D_{mp}$				Deviation of a single outside diameter $\Delta D_s$				Outside diameter variation in a single radial plane $V_{Dp}$			
		Class 0 Class 6X		Class 6 Class 5		Class 4		Class 4		Class 0 Class 6X	Class 6	Class 5	Class 4
Over	Incl.	High	Low	High	Low	High	Low	High	Low	Max	Max	Max	Max
18	30	0	-12	0	-8	0	-6	0	-6	12	8	6	5
30	50	0	-14	0	-9	0	-7	0	-7	14	9	7	5
50	80	0	-16	0	-11	0	-9	0	-9	16	11	8	7
80	120	0	-18	0	-13	0	-10	0	-10	18	13	10	8
120	150	0	-20	0	-15	0	-11	0	-11	20	15	11	8
150	180	0	-25	0	-18	0	-13	0	-13	25	18	14	10
180	250	0	-30	0	-20	0	-15	0	-15	30	20	15	11
250	315	0	-35	0	-25	0	-18	0	-18	35	25	19	14
315	400	0	-40	0	-28	0	-20	0	-20	40	28	22	15
400	500	0	-45	-	-	-	-	-	-	45	-	-	-
500	630	0	-50	-	-	-	-	-	-	50	-	-	-
630	800	0	-75	-	-	-	-	-	-	-	-	-	-
800	1000	0	-100	-	-	-	-	-	-	-	-	-	-

- Remarks: 1. The low deviation of bearing outside diameter specified in this table does not apply within a distance of  $1.2 \times r$  (max) from the ring face.
2. Some of these tolerances conform with the NACHI Standard.

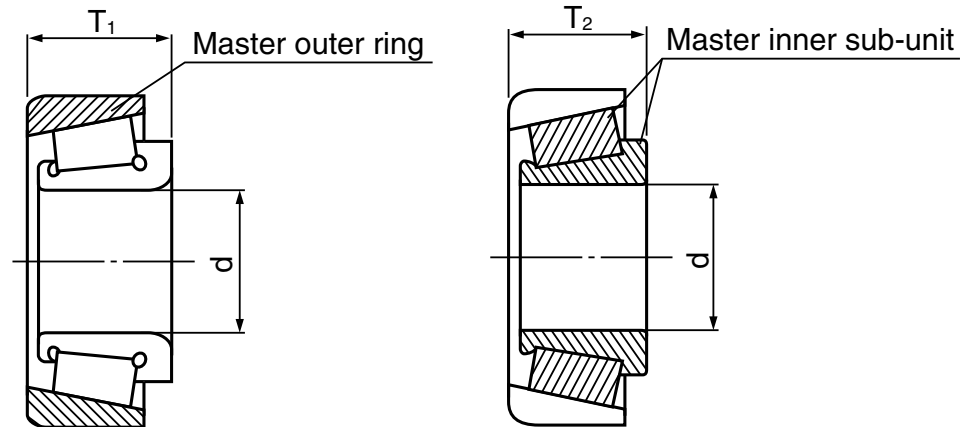

**Table 5.2.2 Tolerance Values of Outer Ring**

(2/2)

Unit:  $\mu\text{m}$



Bearing outside diameter Nominal D (mm)		Bearing outside diameter Mean outside diameter variation $V_{Dmp}$				Radial runout of assembled bearing outer ring $K_{ea}$				Variation of bearing outside surface generatrix inclination with outer ring reference face $S_D$		Assembled bearing outer ring face runout with raceway $S_{ea}$
		Class 0	Class 6	Class 5	Class 4	Class 0	Class 6	Class 5	Class 4	Class 5	Class 4	Class 4
		Class 6X	Class 6	Class 5	Class 4	Class 0	Class 6X	Class 6	Class 5	Class 4	Class 5	Class 4
Over	Incl.	Max	Max	Max	Max	Max	Max	Max	Max	Max	Max	Max
18	30	9	6	5	4	18	9	6	4	8	4	5
30	50	11	7	5	5	20	10	7	5	8	4	5
50	80	12	8	6	5	25	13	8	5	8	4	5
80	120	14	10	7	5	35	18	10	6	9	5	6
120	150	15	11	8	6	40	20	11	7	10	5	7
150	180	19	14	9	7	45	23	13	8	10	5	8
180	250	23	15	10	8	50	25	15	10	11	7	10
250	315	26	19	13	9	60	30	18	11	13	8	10
315	400	30	21	14	10	70	35	20	13	13	10	13
400	500	34	—	—	—	80	—	—	—	—	—	—
500	630	38	—	—	—	100	—	—	—	—	—	—
630	800	—	—	—	—	120	—	—	—	—	—	—
800	1000	—	—	—	—	120	—	—	—	—	—	—

- Remarks: 1. The low deviation of bearing outside diameter specified in this table does not apply within a distance of  $1.2 \times r$  (max) from the ring face.
2. Some of these tolerances conform with the NACHI Standard.

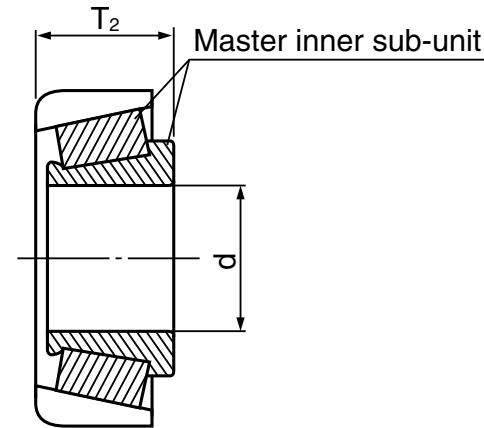
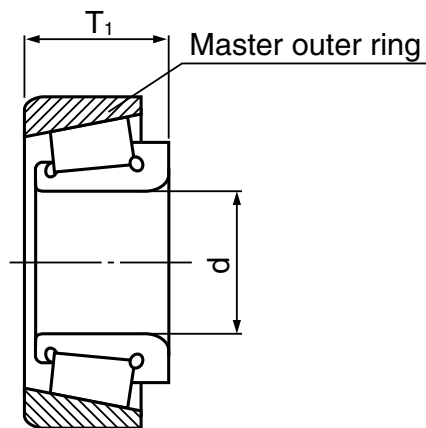

**Table 5.2.3 Deviations of Single Ring Width,  
Bearing Width and Duplex/Stack Mounted Bearing Width**

Unit:  $\mu\text{m}$ 

Bearing bore diameter Nominal d (mm)		Deviation of a single inner ring width $\Delta B_s$						Deviation of a single outer ring width $\Delta C_s$					
		Class 0 Class 6		Class 6X		Class 5 Class 4		Class 0 Class 6		Class 6X		Class 5 Class 4	
		Over	Incl.	High	Low	High	Low	High	Low	High	Low	High	Low
10	18	0	-120	0	-50	0	-200	0	-120	0	-100	0	-200
18	30	0	-120	0	-50	0	-200	0	-120	0	-100	0	-200
30	50	0	-120	0	-50	0	-240	0	-120	0	-100	0	-240
50	80	0	-150	0	-50	0	-300	0	-150	0	-100	0	-300
80	120	0	-200	0	-50	0	-400	0	-200	0	-100	0	-400
120	180	0	-250	0	-50	0	-500	0	-250	0	-100	0	-500
180	250	0	-300	0	-50	0	-600	0	-300	0	-100	0	-600
250	315	0	-350	0	-50	-	-	0	-350	0	-100	-	-
315	400	0	-400	0	-50	-	-	0	-400	0	-100	-	-
400	500	0	-450	-	-	-	-	0	-450	-	-	-	-
500	630	0	-500	-	-	-	-	0	-500	-	-	-	-
630	800	0	-750	-	-	-	-	0	-750	-	-	-	-

Remarks: Effective width of an inner sub-unit  $T_1$  is the bearing width obtained when this sub-unit is mated with a master outer ring.  
Effective width of an outer ring  $T_2$  is the bearing width obtained when this ring is mated with a master inner sub-unit.





**Table 5.2.3 Deviations of Single Ring Width,  
Bearing Width and Duplex/Stack Mounted Bearing Width**

Unit:  $\mu\text{m}$ 

Bearing bore diameter Nominal d (mm)		Deviation of a actual bearing width $\Delta T_s$						Deviation of the actual effective width of inner sub-unit $\Delta T_{1s}$			
		Class 0 Class 6		Class 6X		Class 5 Class 4		Class 0		Class 6X	
Over	Incl.	High	Low	High	Low	High	Low	High	Low	High	Low
10	18	+200	0	+100	0	+200	-200	+100	0	+ 50	0
18	30	+200	0	+100	0	+200	-200	+100	0	+ 50	0
30	50	+200	0	+100	0	+200	-200	+100	0	+ 50	0
50	80	+200	0	+100	0	+200	-200	+100	0	+ 50	0
80	120	+200	-200	+100	0	+200	-200	+100	-100	+ 50	0
120	180	+350	-250	+150	0	+350	-250	+150	-150	+ 50	0
180	250	+350	-250	+150	0	+350	-250	+150	-150	+ 50	0
250	315	+350	-250	+200	0	-	-	+150	-150	+100	0
315	400	+400	-400	+200	0	-	-	+200	-200	+100	0
400	500	+400	-400	-	-	-	-	-	-	-	-
500	630	+500	-500	-	-	-	-	-	-	-	-
630	800	+600	-600	-	-	-	-	-	-	-	-

Remarks: Effective width of an inner sub-unit  $T_1$  is the bearing width obtained when this sub-unit is mated with a master outer ring.  
Effective width of an outer ring  $T_2$  is the bearing width obtained when this ring is mated with a master inner sub-unit.





**Table 5.2.3 Deviations of Single Ring Width,  
Bearing Width and Duplex/Stack Mounted Bearing Width**

Unit:  $\mu\text{m}$ 

Bearing bore diameter Nominal d (mm)		Deviation of the actual effective width of outer sub-unit $\Delta T_{2s}$				Deviation of duplex/stack mounted bearing width			
		Class 0		Class 6X		$\Delta B_{1s}$ Duplex mounted bearing class 0		$\Delta B_{2s} \bullet \Delta C_{2s}$ Four row bearing class 0	
Over	Incl.	High	Low	High	Low	High	Low	High	Low
10	18	+100	0	+ 50	0	+ 200	- 200	-	-
18	30	+100	0	+ 50	0	+ 200	- 200	-	-
30	50	+100	0	+ 50	0	+ 240	- 240	-	-
50	80	+100	0	+ 50	0	+ 300	- 300	+ 400	- 400
80	120	+100	-100	+ 50	0	+ 400	- 400	+ 500	- 500
120	180	+200	-100	+100	0	+ 500	- 500	+ 600	- 600
180	250	+200	-100	+100	0	+ 600	- 600	+ 750	- 750
250	315	+200	-100	+100	0	+ 700	- 700	+ 900	- 900
315	400	+200	-200	+100	0	+ 800	- 800	+1000	-1000
400	500	-	-	-	-	+ 900	- 900	+1200	-1200
500	630	-	-	-	-	+1000	-1000	+1200	-1200
630	800	-	-	-	-	+1500	-1500	+1500	-1500

Remarks: Effective width of an inner sub-unit  $T_1$  is the bearing width obtained when this sub-unit is mated with a master outer ring.  
Effective width of an outer ring  $T_2$  is the bearing width obtained when this ring is mated with a master inner sub-unit.

**Table 5.3.1 Tolerance Values of Shaft Washer Bore Diameter**

Unit:  $\mu\text{m}$

Bearing bore diameter Nominal d or d <sub>2</sub> (mm)		Single plane mean bore diameter deviation				Bore diameter variation, in a single radial plane		Washer thickness (raceway to back face or raceway) variation (1)			
		$\Delta d_{mp}$ or $\Delta d_{2mp}$		Class 4		Class 0		S <sub>i</sub> (or S <sub>e</sub> )			
Over	Incl.	High	Low	High	Low	Max	Max	Max	Max	Max	Max
–	18	0	– 8	0	– 7	6	5	10	5	3	2
18	30	0	– 10	0	– 8	8	6	10	5	3	2
30	50	0	– 12	0	– 10	9	8	10	6	3	2
50	80	0	– 15	0	– 12	11	9	10	7	4	3
80	120	0	– 20	0	– 15	15	11	15	8	4	3
120	180	0	– 25	0	– 18	19	14	15	9	5	4
180	250	0	– 30	0	– 22	23	17	20	10	5	4
250	315	0	– 35	0	– 25	26	19	25	13	7	5
315	400	0	– 40	0	– 30	30	23	30	15	7	5
400	500	0	– 45	0	– 35	34	26	30	18	9	6
500	630	0	– 50	0	– 40	38	30	35	21	11	7
630	800	0	– 75	0	– 50	–	–	40	25	13	8
800	1000	0	– 100	–	–	–	–	45	30	15	–
1000	1250	0	– 125	–	–	–	–	50	35	18	–

**Table 5.3.2 Tolerance Values of Housing Washer Outside Diameter**

Unit:  $\mu\text{m}$

Bearing outside diameter Nominal D (mm)		Mean outside diameter deviation, in a single plane				Outside diameter variation in a single radial plane		
		$\Delta D_{mp}$		Class 4		V <sub>DP</sub>		
Over	Incl.	High	Low	High	Low	Max	Max	Max
10	18	0	– 11	0	– 7	8	5	
18	30	0	– 13	0	– 8	10	6	
30	50	0	– 16	0	– 9	12	7	
50	80	0	– 19	0	– 11	14	8	
80	120	0	– 22	0	– 13	17	10	
120	180	0	– 25	0	– 15	19	11	
180	250	0	– 30	0	– 20	23	15	
250	315	0	– 35	0	– 25	26	19	
315	400	0	– 40	0	– 28	30	21	
400	500	0	– 45	0	– 33	34	25	
500	630	0	– 50	0	– 38	38	29	
630	800	0	– 75	0	– 45	55	34	
800	1000	0	– 100	–	–	75	–	
1000	1250	0	– 125	–	–	–	–	
1250	1600	0	– 160	–	–	–	–	

Note: (1) For double acting bearings, use size classification d, not d<sub>2</sub>.

Raceway to back face thickness variation of housing washer S<sub>e</sub> applies to the bearing with seat.

**Table 5.3.3 Height Tolerances of Thrust Ball Bearings (with Flat Seat) and Center Washers (Class 0) Unit:  $\mu\text{m}$**

Bearing bore diameter Nominal d (mm)		Deviation of single height, T $\Delta T_s$		Deviation of single height, T <sub>2</sub> of double direction thrust bearing (1) $\Delta T_{2s}$		Deviation of single height, T <sub>1</sub> of double direction thrust bearing (1) $\Delta T_{1s}$		Deviation of center washer height (1) $\Delta B_s$	
Over	Incl.	High	Low	High	Low	High	Low	High	Low
—	30	0	-75	0	-75	+50	-150	0	-50
30	50	0	-100	0	-100	+75	-200	0	-75
50	80	0	-125	0	-125	+100	-250	0	-100
80	120	0	-150	0	-150	+125	-300	0	-125
120	180	0	-175	0	-175	+150	-350	0	-150
180	250	0	-200	0	-200	+175	-400	0	-175
250	315	0	-225	0	-225	+200	-450	0	-200
315	400	0	-300	0	-300	+250	-600	0	-250

Note: (1) For double acting bearings, use size classification d, not d<sub>2</sub>.  
 (2) Height deviations  $\Delta T_s$ ,  $\Delta T_{1s}$ ,  $\Delta T_{2s}$  apply to the bearings with flat seat.

**Table 5.4.1 Tolerance Values of Inner Rings Unit:  $\mu\text{m}$**

Bearing bore diameter Nominal d (mm)		Single plane mean bore diameter deviation $\Delta d_{mp}$		Bore diameter variation, in a single radial plane $V_{dp}$	Inner ring reference face runout with bore $S_d$	References	
Over	Incl.	High	Low			High	Low
50	80	0	-15	11	25	+150	-150
80	120	0	-20	15	25	+200	-200
120	180	0	-25	19	30	+250	-250
180	250	0	-30	23	30	+300	-300
250	315	0	-35	26	35	+350	-350
315	400	0	-40	30	40	+400	-400
400	500	0	-45	34	45	+450	-450

**Table 5.4.2 Tolerance Values of Outer Rings Unit:  $\mu\text{m}$**

Bearing bore diameter Nominal D (mm)		Outside diameter deviation $\Delta D_{mp}$	
Over	Incl.	High	Low
120	180	0	-25
180	250	0	-30
250	315	0	-35
315	400	0	-40
400	500	0	-45
500	630	0	-50
630	800	0	-75
800	1000	0	-100

Remarks: The high deviation of bearing bore diameter specified in this table does not apply within a distance of  $1.2 \times r$  (max) from the ring face.  
 The low deviation of bearing outside diameter specified in this table does not apply within a distance of  $1.2 \times r$  (max) from the ring face.

**Table 5.5.1 Tolerance of Inner Ring (Cone) Bore**Unit:  $\mu\text{m}$ 

Bearing bore diameter Nominal d mm (inch)		Deviation of single bore diameter $\Delta d_s$							
		Class 4		Class 3		Class 0		Class 00	
Over	Incl.	High	Low	High	Low	High	Low	High	Low
–	76.200 ( 3 )	+ 13	0	+13	0	+13	0	+8	0
76.200 ( 3 )	304.800 (12)	+ 25	0	+13	0	+13	0	+8	0
304.800 (12)	609.600 (24)	+ 51	0	+25	0	–	–	–	–
609.600 (24)	914.400 (36)	+ 76	0	+38	0	–	–	–	–
914.400 (36)	1219.200 (48)	+102	0	+51	0	–	–	–	–
1219.200 (48)	–	+127	0	+76	0	–	–	–	–

**Table 5.5.2 Tolerance of Outer Ring (Cup) Outside Diameter**Unit:  $\mu\text{m}$ 

Bearing outside diameter Nominal D mm (inch)		Deviation of single outside diameter $\Delta D_s$							
		Class 4		Class 3		Class 0		Class 00	
Over	Incl.	High	Low	High	Low	High	Low	High	Low
–	304.800 (12)	+ 25	0	+13	0	+13	0	+8	0
304.800 (12)	609.600 (24)	+ 51	0	+25	0	–	–	–	–
609.600 (24)	914.400 (36)	+ 76	0	+38	0	–	–	–	–
914.400 (36)	1219.200 (48)	+102	0	+51	0	–	–	–	–
1219.200 (48)	–	+127	0	+76	0	–	–	–	–

**Table 5.5.3 Tolerance of Bearing Width and Duplex/Stack Mounted Bearing Width**

Unit:  $\mu\text{m}$

Bearing bore diameter Nominal d mm (inch)		Bearing outside diameter Nominal D mm (inch)		Deviation of the actual bearing width $\Delta T_s$					
				Class 4		Class 3		Class 0 Class 00	
Over	Incl.	Over	Incl.	High	Low	High	Low	High	Low
–	101.600 ( 4 )	–	–	+203	0	+203	–203	+203	–203
101.600 ( 4 )	304.800 (12)	–	–	+356	–254	+203	–203	+203	–203
304.800 (12)	609.600 (24)	–	508.000 (20)	+381	–381	+203	–203	–	–
304.800 (12)	609.600 (24)	508.000 (20)	–	+381	–381	+381	–381	–	–
609.600 (24)	–	–	–	+381	–381	+381	–381	–	–

Note: (1) Deviation of the actual bearing width  $B_2$ , and  $C_2$  for row tapered roller bearing is  $\pm 1524 \mu\text{m}$  for the tolerance classes of 4, 3 and 0.

**Table 5.5.4 Radial Runout of Assembled Bearing Inner Ring and Outer Ring**

Unit:  $\mu\text{m}$

Bearing outside diameter Nominal D mm (inch)		Radial runout of assembled bearing inner ring $K_{ia}$ and of assembled bearing outer ring $K_{ea}$ (Max)			
Over	Incl.	Class 4	Class 3	Class 0	Class 00
–	304.800 (14)	51	8	4	2
304.800 (12)	609.600 (24)	51	18	–	–
609.600 (24)	914.400 (36)	76	51	–	–
914.400 (36)	–	76	76	–	–

## 5.6 Chamfer Dimension Limits

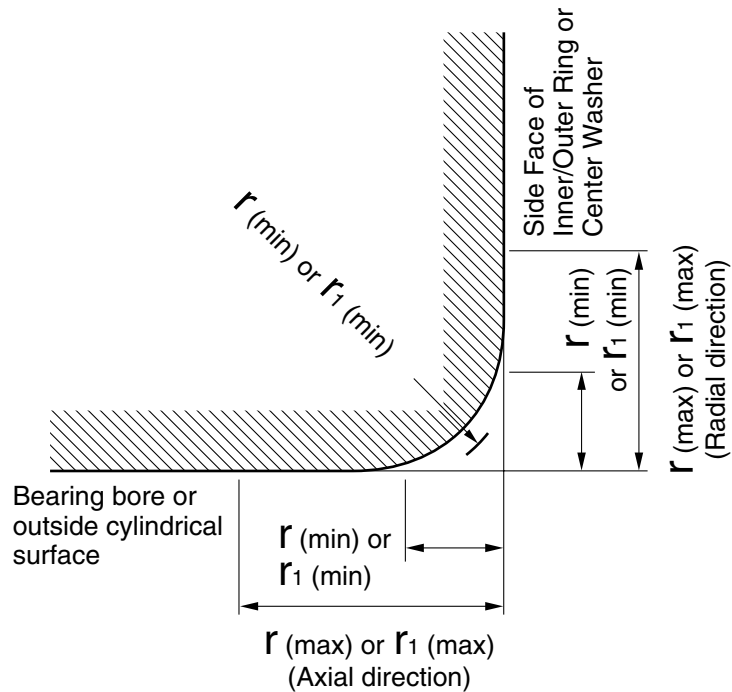

$r$  : Chamfer dimensions of inner ring and outer ring.  
 $r_1$  : Chamfer dimensions of inner ring and outer ring (front face) or of inner ring of double direction thrust bearing.

Remarks: The exact shape of the chamfer surface is not specified, but its contour in an axial plane shall not be allowed to project beyond the imaginary circular arc, of radius  $r$  min, tangential to the ring face and the bore or outside cylindrical surface of the ring (see figure).

**Table 5.6.1 Chamfer Dimension Limits of Radial Bearings Except Tapered Roller Bearings** (1/2)  
 Unit: mm

Smallest permissible chamfer dimensions of inner and outer rings $r$ (min) or $r_1$ (min)	Bearing bore diameter Nominal $d$		Largest permissible chamfer dimensions of inner and outer rings $r$ (max) or $r_1$ (max)		Reference
	Over	Incl.	Radial direction	Axial direction	Shaft and housing fillet radius $r_a$ Max
0.05	—	—	0.1	0.2	0.05
0.08	—	—	0.16	0.3	0.08
0.1	—	—	0.2	0.4	0.1
0.15	—	—	0.3	0.6	0.15
0.2	—	—	0.5	0.8	0.2
0.3	— 40	40 —	0.6 0.8	1 1	0.3
0.6	— 40	40 —	1 1.3	2 2	0.6
1	— 50	50 —	1.5 1.9	3 3	1
1.1	— 120	120 —	2 2.5	3.5 4	1
1.5	— 120	120 —	2.3 3	4 5	1.5

Remarks: For bearings with a width of 2mm or less the  $r$  max values for the radial direction apply also in the axial direction.

[Continue→]

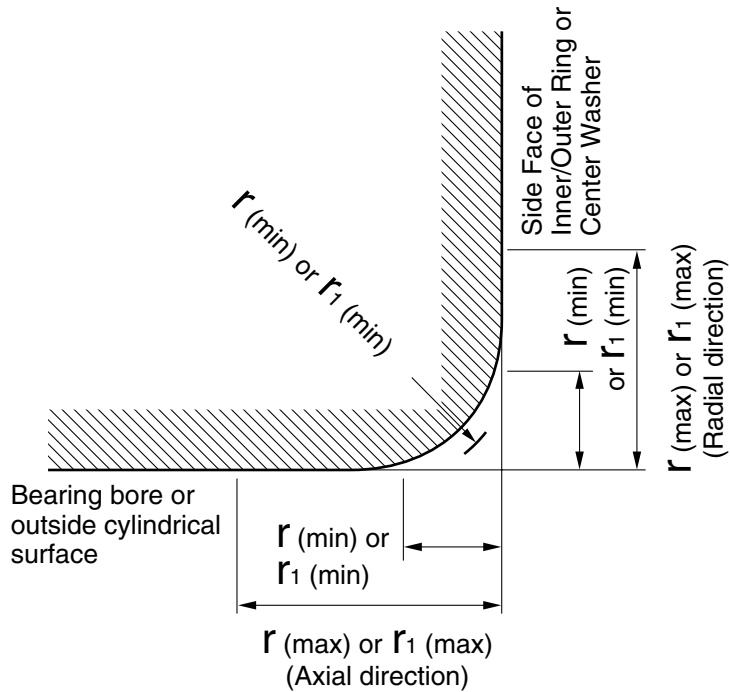

$r$  : Chamfer dimensions of inner ring and outer ring.  
 $r_1$  : Chamfer dimensions of inner ring and outer ring (front face) or of inner ring of double direction thrust bearing.

Remarks: The exact shape of the chamfer surface is not specified, but its contour in an axial plane shall not be allowed to project beyond the imaginary circular arc, of radius  $r$  min, tangential to the ring face and the bore or outside cylindrical surface of the ring (see figure).

**Table 5.6.1 Chamfer Dimension Limits of Radial Bearings Except Tapered Roller Bearings**

Unit: mm

Smallest permissible chamfer dimensions of inner and outer rings $r$ (min) or $r_1$ (min)	Bearing bore diameter Nominal $d$		Largest permissible chamfer dimensions of inner and outer rings $r$ (max) or $r_1$ (max)		Reference
	Over	Incl.			Shaft and housing fillet radius $r_a$ Max
			Radial direction	Axial direction	
2	–	80	3	4.5	2
	80	220	3.5	5	
	220	–	3.8	6	
2.1	–	280	4	6.5	2
	280	–	4.5	7	
	–	–	–	–	
2.5	–	100	3.8	6	2
	100	280	4.5	6	
	280	–	5	7	
3	–	280	5	8	2.5
	280	–	5.5	8	
	–	–	–	–	
4	–	–	6.5	9	3
	–	–	8	10	
	–	–	–	–	
5	–	–	10	13	5
	–	–	12.5	17	
	–	–	15	19	
6	–	–	18	24	10
	–	–	21	30	
	–	–	25	38	
7.5	–	–	–	–	6
	–	–	–	–	
	–	–	–	–	
9.5	–	–	–	–	8
	–	–	–	–	
	–	–	–	–	
12	–	–	–	–	12
	–	–	–	–	
	–	–	–	–	
15	–	–	–	–	15
	–	–	–	–	
	–	–	–	–	
19	–	–	–	–	15
	–	–	–	–	
	–	–	–	–	

Remarks: For bearings with a width of 2mm or less the  $r$  max values for the radial direction apply also in the axial direction.





**Table 5.6.2 Chamfer Dimension Limits of Tapered Roller Bearings** Unit: mm

Smallest permissible chamfer dimensions of inner and outer rings $r$ (min)	Bearing bore diameter or outside diameter (1) d or D		Largest permissible chamfer dimensions of inner and outer rings $r$ (max)		Reference
	Over	Incl.	Radial direction	Axial direction	Shaft and housing fillet radius $r_a$
					Max
0.3	– 40	40 –	0.7 0.9	1.4 1.6	0.3
0.6	– 40	40 –	1.1 1.3	1.7 2	0.6
1	– 50	50 –	1.6 1.9	2.5 3	1
1.5	– 120 250	120 250 –	2.3 2.8 3.5	3 3.5 4	1.5
2	– 120 250	120 250 –	2.8 3.5 4	4 4.5 5	2
2.5	– 120 250	120 250 –	3.5 4 4.5	5 5.5 6	2
3	– 120 250 400	120 250 400 –	4 4.5 5 5.5	5.5 6.5 7 7.5	2.5
4	– 120 250 400	120 250 400 –	5 5.5 6 6.5	7 7.5 8 8.5	3
5	– 180	180 –	6.5 7.5	8 9	4
6	– 180	180 –	7.5 9	10 11	5

**Table 5.6.3 Chamfer Dimension Limits of Thrust Bearings** Unit: mm

Smallest permissible chamfer dimensions of inner and outer rings $r$ (min) or $r_1$ (min)	Largest permissible single chamfer dimensions of inner and outer rings $r$ (max) or $r_1$ (max)	Reference
		Shaft and housing fillet radius $r_a$
	Radial direction and axial direction	Max
0.05 0.08 0.1	0.1 0.16 0.2	0.05 0.08 0.1
0.15 0.2 0.3	0.3 0.5 0.8	0.15 0.2 0.3
0.6 1 1.1	1.5 2.2 2.7	0.6 1 1
1.5 2 2.1	3.5 4 4.5	1.5 2 2
3 4 5	5.5 6.5 8	2.5 3 4
6 7.5 9.5	10 12.5 15	5 6 8
12 15 19	18 21 25	10 12 15

Note: (1) d and D are applied to inner ring and outer ring respectively.



# 5.7 Tolerances for Tapered Bores

$d$ : Bearing bore diameter, nominal

$d_1$ : Basic diameter at the theoretical large end of a tapered bore

in case of 1/12 taper  $d_1 = d + \frac{1}{12}B$

in case of 1/30 taper  $d_1 = d + \frac{1}{30}B$

$\Delta d_{mp}$ : Mean bore diameter deviation at theoretical small end of a tapered bore

$\Delta d_{1mp}$ : Mean bore diameter deviation at theoretical large end of a tapered bore

$B$ : Bearing inner ring width, nominal

$\alpha$ : Nominal taper angle (half of cone angle)

in case of 1/12 taper  $\alpha = 2^\circ 23' 9.4''$   
 $= 2.38594^\circ$   
 $= 0.041643 \text{ rad}$

in case of 1/30 taper  $\alpha = 0^\circ 57' 17.4''$   
 $= 0.95484^\circ$

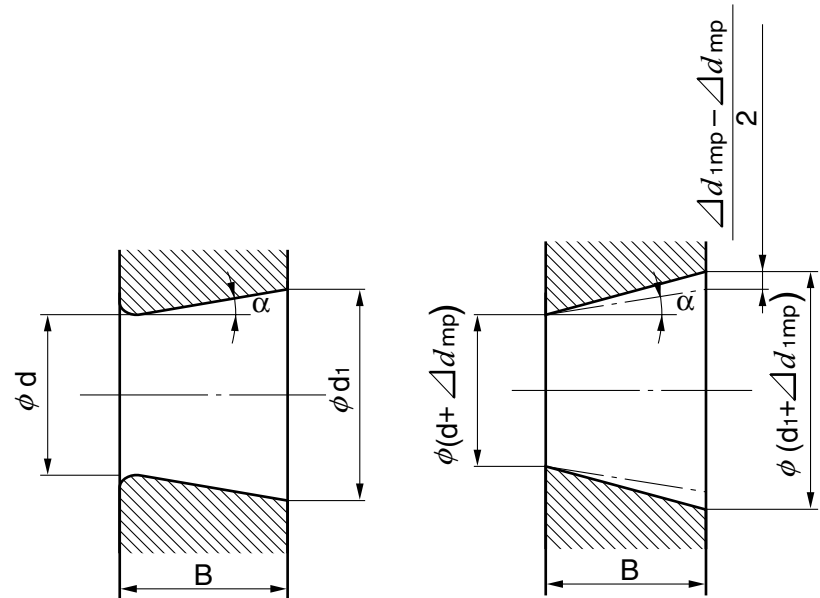

**Theoretical tapered bore**

**Tapered bore with actual mean diameters at their deviations**

**Table 5.7.1 1/12 Tapered Bore (Class 0)**

**Table 5.7.2 1/30 Tapered Bore (Class 0)**

**Table 5.7.1 1/12 Tapered Bore (Class 0)**

Unit:  $\mu\text{m}$

Nominal bearing bore dimension d (mm)		Mean bore diameter deviation at theoretical small end of a tapered bore				Bore diameter variation in a single radial plane (1)(2)	
		$\Delta d_{mp}$		$\Delta d_{1mp} - \Delta d_{mp}$		$Vd_p$	
Over	Incl.	High	Low	High	Low	Max	
	10	+ 22	0	+ 15	0	9	
10	18	+ 27	0	+ 18	0	11	
18	30	+ 33	0	+ 21	0	13	
30	50	+ 39	0	+ 25	0	16	
50	80	+ 46	0	+ 30	0	19	
80	120	+ 54	0	+ 35	0	22	
120	180	+ 63	0	+ 40	0	40	
180	250	+ 72	0	+ 46	0	46	
250	315	+ 81	0	+ 52	0	52	
315	400	+ 89	0	+ 57	0	57	
400	500	+ 97	0	+ 63	0	63	
500	630	+110	0	+ 70	0	70	
630	800	+125	0	+ 80	0	—	
800	1000	+140	0	+ 90	0	—	
1000	1250	+165	0	+105	0	—	
1250	1600	+195	0	+125	0	—	

Note: (1) Applicable to all radial planes of tapered bore.

(2) Not applicable to bearings of diameter series 7 and 8.

**Table 5.7.2 1/30 Tapered Bore (Class 0)**

Unit:  $\mu\text{m}$

Nominal bearing bore dimension d (mm)		Mean bore diameter deviation at theoretical small end of a tapered bore				Bore diameter variation in a single radial plane (1)(2)	
		$\Delta d_{mp}$		$\Delta d_{1mp} - \Delta d_{mp}$		$Vd_p$	
Over	Incl.	High	Low	High	Low	Max	
50	80	+15	0	+30	0	19	
80	120	+20	0	+35	0	22	
120	180	+25	0	+40	0	40	
180	250	+30	0	+46	0	46	
250	315	+35	0	+52	0	52	
315	400	+40	0	+57	0	57	
400	500	+45	0	+63	0	63	
500	630	+50	0	+70	0	70	

Note: (1) Applicable to all radial planes of tapered bore.

(2) Not applicable to bearings of diameter series 7 and 8.

**Table 5.1.1 Tolerance Values of Inner Ring and of Outer Ring Width**

(1/4)

Unit:  $\mu\text{m}$

Bearing bore diameter Nominal d (mm)		Bearing with cylindrical bore													
		Single plane mean bore diameter deviation $\Delta d_{mp}$										Deviation of a single bore diameter (2) $\Delta d_s$			
		Class 0		Class 6		Class 5		Class 4		Class 2		Class 4 Diameter series 0,1,2,3,4		Class 2	
		High	Low	High	Low	High	Low	High	Low	High	Low	High	Low	High	Low
0.6 <sup>(1)</sup>	2.5	0	-8	0	-7	0	-5	0	-4	0	-2.5	0	-4	0	-2.5
2.5	10	0	-8	0	-7	0	-5	0	-4	0	-2.5	0	-4	0	-2.5
10	18	0	-8	0	-7	0	-5	0	-4	0	-2.5	0	-4	0	-2.5
18	30	0	-10	0	-8	0	-6	0	-5	0	-2.5	0	-5	0	-2.5
30	50	0	-12	0	-10	0	-8	0	-6	0	-2.5	0	-6	0	-2.5
50	80	0	-15	0	-12	0	-9	0	-7	0	-4	0	-7	0	-4
80	120	0	-20	0	-15	0	-10	0	-8	0	-5	0	-8	0	-5
120	150	0	-25	0	-18	0	-13	0	-10	0	-7	0	-10	0	-7
150	180	0	-25	0	-18	0	-13	0	-10	0	-7	0	-10	0	-7
180	250	0	-30	0	-22	0	-15	0	-12	0	-8	0	-12	0	-8
250	315	0	-35	0	-25	0	-18	-	-	-	-	-	-	-	-
315	400	0	-40	0	-30	0	-23	-	-	-	-	-	-	-	-
400	500	0	-45	0	-35	-	-	-	-	-	-	-	-	-	-
500	630	0	-50	0	-40	-	-	-	-	-	-	-	-	-	-
630	800	0	-75	-	-	-	-	-	-	-	-	-	-	-	-
800	1000	0	-100	-	-	-	-	-	-	-	-	-	-	-	-
1000	1250	0	-125	-	-	-	-	-	-	-	-	-	-	-	-
1250	1600	0	-160	-	-	-	-	-	-	-	-	-	-	-	-
1600	2000	0	-200	-	-	-	-	-	-	-	-	-	-	-	-

Notes: (1) This diameter is included in this group.

(2) Applies to bearings with cylindrical bore.

(3) Width deviation and variation of outer ring are the same with of inner ring. Outer ring width variation of classes 5, 4 and 2 are listed in Table 5.1.2.

(4) Applies to the rings of single bearings made for paired of stack mounting.

(5) Applies to radial ball bearings such as deep groove ball bearing, angular contact ball bearings.

Remarks: The high deviation of bearing cylindrical bore diameter specified in this table does not apply within a distance of  $1.2 \times r$  (max) from the ring face.



**Table 5.1.1 Tolerance Values of Inner Ring and of Outer Ring Width**

(2/4)

Unit:  $\mu\text{m}$

Bearing bore diameter Nominal d (mm)		Bearing with cylindrical bore																					
		Bore diameter variation in a single radial plane (2)										Main bore diameter variation (2)											
		$Vd_p$																					
		Class 0			Class 6			Class 5		Class 4		Class 2		Class 0		Class 6		Class 5		Class 4		Class 2	
		Diameter series			Diameter series			Diameter series		Diameter series		Class 2		Class 0		Class 6		Class 5		Class 4		Class 2	
Over	Incl.	7,8,9	0,1	2,3,4	7,8,9	0,1	2,3,4	7,8,9	0,1,2,3,4	7,8,9	0,1,2,3,4	Max	Max	Max	Max	Max	Max	Max	Max	Max	Max		
0.6 <sup>(1)</sup>	2.5	10	8	6	9	7	5	5	4	4	3	2.5	6	5	3	2	1.5						
2.5	10	10	8	6	9	7	5	5	4	4	3	2.5	6	5	3	2	1.5						
10	18	10	8	6	9	7	5	5	4	4	3	2.5	6	5	3	2	1.5						
18	30	13	10	8	10	8	6	6	5	5	4	2.5	8	6	3	2.5	1.5						
30	50	15	12	9	13	10	8	8	6	6	5	2.5	9	8	4	3	1.5						
50	80	19	19	11	15	15	9	9	7	7	5	4	11	9	5	3.5	2						
80	120	25	25	15	19	19	11	10	8	8	6	5	15	11	5	4	2.5						
120	150	31	31	19	23	23	14	13	10	10	8	7	19	14	7	5	3.5						
150	180	31	31	19	23	23	14	13	10	10	8	7	19	14	7	5	3.5						
180	250	38	38	23	28	28	17	15	12	12	9	8	23	17	8	6	4						
250	315	44	44	26	31	31	19	18	14	—	—	—	26	19	9	—	—						
315	400	50	50	30	38	38	23	23	18	—	—	—	30	23	12	—	—						
400	500	56	56	34	44	44	26	—	—	—	—	—	34	26	—	—	—						
500	630	63	63	38	50	50	30	—	—	—	—	—	38	30	—	—	—						
630	800	—	—	—	—	—	—	—	—	—	—	—	—	—	—	—	—						
800	1000	—	—	—	—	—	—	—	—	—	—	—	—	—	—	—	—						
1000	1250	—	—	—	—	—	—	—	—	—	—	—	—	—	—	—	—						
1250	1600	—	—	—	—	—	—	—	—	—	—	—	—	—	—	—	—						
1600	2000	—	—	—	—	—	—	—	—	—	—	—	—	—	—	—	—						

- Notes: (1) This diameter is included in this group.  
 (2) Applies to bearings with cylindrical bore.  
 (3) Width deviation and variation of outer ring are the same with of inner ring. Outer ring width variation of classes 5, 4 and 2 are listed in Table 5.1.2.  
 (4) Applies to the rings of single bearings made for paired of stack mounting.  
 (5) Applies to radial ball bearings such as deep groove ball bearing, angular contact ball bearings.

Remarks: The high deviation of bearing cylindrical bore diameter specified in this table does not apply within a distance of  $1.2 \times r$  (max) from the ring face.

**Table 5.1.1 Tolerance Values of Inner Ring and of Outer Ring Width**

(3/4)

Unit:  $\mu\text{m}$

Bearing bore diameter Nominal d (mm)		Deviation of a single inner ring width (or a single outer ring width) (2) $\Delta B_s$ (or $\Delta C_s$ )										Inner (or outer) ring width variation $V_{BS}$ (or $V_{CS}$ )				
		Single bearing						Paired or stack mounted bearing (4)				Inner ring (or outer ring) (3)		Inner ring		
		Class 0 Class 6		Class 5 Class 4		Class 2		Class 0 Class 6		Class 5 Class 4		Class 0	Class 6	Class 5	Class 4	Class 2
Over	Incl.	High	Low	High	Low	High	Low	High	Low	High	Low	Max	Max	Max	Max	Max
0.6 <sup>(1)</sup>	2.5	0	-40	0	-40	0	-40	-	-	0	-250	12	12	5	2.5	1.5
2.5	10	0	-120	0	-40	0	-40	0	-250	0	-250	15	15	5	2.5	1.5
10	18	0	-120	0	-80	0	-80	0	-250	0	-250	20	20	5	2.5	1.5
18	30	0	-120	0	-120	0	-120	0	-250	0	-250	20	20	5	2.5	1.5
30	50	0	-120	0	-120	0	-120	0	-250	0	-250	20	20	5	3	1.5
50	80	0	-150	0	-150	0	-150	0	-380	0	-250	25	25	6	4	1.5
80	120	0	-200	0	-200	0	-200	0	-380	0	-380	25	25	7	4	2.5
120	150	0	-250	0	-250	0	-250	0	-500	0	-380	30	30	8	5	2.5
150	180	0	-250	0	-250	0	-250	0	-500	0	-380	30	30	8	5	4
180	250	0	-300	0	-300	0	-300	0	-500	0	-500	30	30	10	6	5
250	315	0	-350	0	-350	-	-	0	-500	0	-500	35	35	13	-	-
315	400	0	-400	0	-400	-	-	0	-630	0	-630	40	40	15	-	-
400	500	0	-450	-	-	-	-	-	-	-	-	50	45	-	-	-
500	630	0	-500	-	-	-	-	-	-	-	-	60	50	-	-	-
630	800	0	-750	-	-	-	-	-	-	-	-	70	-	-	-	-
800	1000	0	-1000	-	-	-	-	-	-	-	-	80	-	-	-	-
1000	1250	0	-1250	-	-	-	-	-	-	-	-	100	-	-	-	-
1250	1600	0	-1600	-	-	-	-	-	-	-	-	120	-	-	-	-
1600	2000	0	-2000	-	-	-	-	-	-	-	-	140	-	-	-	-

Notes: (1) This diameter is included in this group.

(2) Applies to bearings with cylindrical bore.

(3) Width deviation and variation of outer ring are the same with of inner ring. Outer ring width variation of classes 5, 4 and 2 are listed in Table 5.1.2.

(4) Applies to the rings of single bearings made for paired of stack mounting.

(5) Applies to radial ball bearings such as deep groove ball bearing, angular contact ball bearings.

Remarks: The high deviation of bearing cylindrical bore diameter specified in this table does not apply within a distance of  $1.2 \times r$  (max) from the ring face.

**Table 5.1.1 Tolerance Values of Inner Ring and of Outer Ring Width**

(4/4)

Unit:  $\mu\text{m}$

Bearing bore diameter Nominal d (mm)		Radial runout of assembled bearing inner ring $K_{ia}$					Inner ring reference face runout with bore $S_d$			Assembled bearing inner ring face runout with raceway $S_{ia}$ (5)		
		Class 0	Class 6	Class 5	Class 4	Class 2	Class 5	Class 4	Class 2	Class 5	Class 4	Class 2
Over	Incl.	Max	Max	Max	Max	Max	Max	Max	Max	Max	Max	Max
0.6 <sup>(1)</sup>	2.5	10	5	4	2.5	1.5	7	3	1.5	7	3	1.5
2.5	10	10	6	4	2.5	1.5	7	3	1.5	7	3	1.5
10	18	10	7	4	2.5	1.5	7	3	1.5	7	3	1.5
18	30	13	8	4	3	2.5	8	4	1.5	8	4	2.5
30	50	15	10	5	4	2.5	8	4	1.5	8	4	2.5
50	80	20	10	5	4	2.5	8	5	1.5	8	5	2.5
80	120	25	13	6	5	2.5	9	5	2.5	9	5	2.5
120	150	30	18	8	6	2.5	10	6	2.5	10	7	2.5
150	180	30	18	8	6	5	10	6	4	10	7	5
180	250	40	20	10	8	5	11	7	5	13	8	5
250	315	50	25	13	—	—	13	—	—	15	—	—
315	400	60	30	15	—	—	15	—	—	20	—	—
400	500	65	35	—	—	—	—	—	—	—	—	—
500	630	70	40	—	—	—	—	—	—	—	—	—
630	800	80	—	—	—	—	—	—	—	—	—	—
800	1000	90	—	—	—	—	—	—	—	—	—	—
1000	1250	100	—	—	—	—	—	—	—	—	—	—
1250	1600	120	—	—	—	—	—	—	—	—	—	—
1600	2000	140	—	—	—	—	—	—	—	—	—	—

Notes: (1) This diameter is included in this group.

(2) Applies to bearings with cylindrical bore.

(3) Width deviation and variation of outer ring are the same with of inner ring. Outer ring width variation of classes 5, 4 and 2 are listed in Table 5.1.2.

(4) Applies to the rings of single bearings made for paired of stack mounting.

(5) Applies to radial ball bearings such as deep groove ball bearing, angular contact ball bearings.

Remarks: The high deviation of bearing cylindrical bore diameter specified in this table does not apply within a distance of  $1.2 \times r$  (max) from the ring face.

**Table 5.1.2 Tolerance Values of Outer Ring**

**(1/4)**

Unit:  $\mu\text{m}$

Bearing outside diameter Nominal D (mm)		Bearing outside diameter													
		Single plane mean outside diameter deviation $\Delta D_{mp}$										Deviation of a single outside diameter $\Delta D_s$			
		Class 0		Class 6		Class 5		Class 4		Class 2		Class 4		Class 2	
		Diameter series 0,1,2,3,4													
Over	Incl.	High	Low	High	Low	High	Low	High	Low	High	Low	High	Low	High	Low
2.5 <sup>(1)</sup>	6	0	-8	0	-7	0	-5	0	-4	0	-2.5	0	-4	0	-2.5
6	18	0	-8	0	-7	0	-5	0	-4	0	-2.5	0	-4	0	-2.5
18	30	0	-9	0	-8	0	-6	0	-5	0	-4	0	-5	0	-4
30	50	0	-11	0	-9	0	-7	0	-6	0	-4	0	-6	0	-4
50	80	0	-13	0	-11	0	-9	0	-7	0	-4	0	-7	0	-4
80	120	0	-15	0	-13	0	-10	0	-8	0	-5	0	-8	0	-5
120	150	0	-18	0	-15	0	-11	0	-9	0	-5	0	-9	0	-5
150	180	0	-25	0	-18	0	-13	0	-10	0	-7	0	-10	0	-7
180	250	0	-30	0	-20	0	-15	0	-11	0	-8	0	-11	0	-8
250	315	0	-35	0	-25	0	-18	0	-13	0	-8	0	-13	0	-8
315	400	0	-40	0	-28	0	-20	0	-15	0	-10	0	-15	0	-10
400	500	0	-45	0	-33	0	-23	-	-	-	-	-	-	-	-
500	630	0	-50	0	-38	0	-28	-	-	-	-	-	-	-	-
630	800	0	-75	0	-45	0	-35	-	-	-	-	-	-	-	-
800	1000	0	-100	0	-60	-	-	-	-	-	-	-	-	-	-
1000	1250	0	-125	-	-	-	-	-	-	-	-	-	-	-	-
1250	1600	0	-160	-	-	-	-	-	-	-	-	-	-	-	-
1600	2000	0	-200	-	-	-	-	-	-	-	-	-	-	-	-
2000	2500	0	-250	-	-	-	-	-	-	-	-	-	-	-	-

- Notes: (1) This diameter is included in this group.  
 (2) Applies before mounting and after removal of internal or external snap ring.  
 (3) Applies to radial ball bearings such as deep groove ball bearings, angular contact ball bearings.  
 (4) Outer ring width variation of class 0 and 6 are listed in Table 5.1.1.  
 (5) Applies to radial ball bearings such as deep groove ball bearing, angular contact ball bearings.

Remarks: The high deviation of bearing cylindrical bore diameter specified in this table does not apply within a distance of  $1.2 \times r$  (max) from the ring face.



**Table 5.1.2 Tolerance Values of Outer Ring**

(2/4)

Unit:  $\mu\text{m}$

Bearing outside diameter Nominal D (mm)		Bearing outside diameter												
		Outside diameter variation in a single radial plane (2)												
		$V_{Dp}$												
		Class 0				Class 6				Class 5		Class 4		Class 2
		Open bearing		Seal · shield bearing		Open bearing		Seal · shield bearing		Open bearing		Open bearing		Open bearing
Diameter series		Diameter series		Diameter series		Diameter series		Diameter series		Diameter series		Diameter series		Open bearing
7,8,9	0,1	2,3,4	2,3,4	7,8,9	0,1	2,3,4	0,1,2,3,4	7,8,9	0,1,2,3,4	7,8,9	0,1,2,3,4	7,8,9	0,1,2,3,4	Open bearing
Over	Incl.	Max	Max	Max	Max	Max	Max	Max	Max	Max	Max	Max	Max	Max
2.5 <sup>(1)</sup>	6	10	8	6	10	9	7	5	9	5	4	4	3	2.5
6	18	10	8	6	10	9	7	5	9	5	4	4	3	2.5
18	30	12	9	7	12	10	8	6	10	6	5	5	4	4
30	50	14	11	8	16	11	9	7	13	7	5	6	5	4
50	80	16	13	10	20	14	11	8	16	9	7	7	5	4
80	120	19	19	11	26	16	16	10	20	10	8	8	6	5
120	150	23	23	14	30	19	19	11	25	11	8	9	7	5
150	180	31	31	19	38	23	23	14	30	13	10	10	8	7
180	250	38	38	23	—	25	25	15	—	15	11	11	8	8
250	315	44	44	26	—	31	31	19	—	18	14	13	10	8
315	400	50	50	30	—	35	35	21	—	20	15	15	11	10
400	500	56	56	34	—	41	41	25	—	23	17	—	—	—
500	630	63	63	38	—	48	48	29	—	28	21	—	—	—
630	800	94	94	55	—	56	56	34	—	35	26	—	—	—
800	1000	125	125	75	—	75	75	45	—	—	—	—	—	—
1000	1250	—	—	—	—	—	—	—	—	—	—	—	—	—
1250	1600	—	—	—	—	—	—	—	—	—	—	—	—	—
1600	2000	—	—	—	—	—	—	—	—	—	—	—	—	—
2000	2500	—	—	—	—	—	—	—	—	—	—	—	—	—

- Notes: (1) This diameter is included in this group.  
 (2) Applies before mounting and after removal of internal or external snap ring.  
 (3) Applies to radial ball bearings such as deep groove ball bearings, angular contact ball bearings.  
 (4) Outer ring width variation of class 0 and 6 are listed in Table 5.1.1.  
 (5) Applies to radial ball bearings such as deep groove ball bearing, angular contact ball bearings.

Remarks: The high deviation of bearing cylindrical bore diameter specified in this table does not apply within a distance of  $1.2 \times r$  (max) from the ring face.

**Table 5.1.2 Tolerance Values of Outer Ring**

(3/4)

Unit:  $\mu\text{m}$

Bearing outside diameter Nominal D (mm)		Bearing outside diameter					Radial runout of assembled bearing outer ring					Variation of bearing outside surface generatrix inclination with outer ring reference face		
		Mean outside diameter variation (2)					Kea					SD		
		Class 0	Class 6	Class 5	Class 4	Class 2	Class 0	Class 6	Class 5	Class 4	Class 2	Class 5	Class 4	Class 2
Over	Incl.	Max	Max	Max	Max	Max	Max	Max	Max	Max	Max	Max	Max	
2.5 <sup>(1)</sup>	6	6	5	3	2	1.5	15	8	5	3	1.5	8	4	1.5
6	18	6	5	3	2	1.5	15	8	5	3	1.5	8	4	1.5
18	30	7	6	3	2.5	2	15	9	6	4	2.5	8	4	1.5
30	50	8	7	4	3	2	20	10	7	5	2.5	8	4	1.5
50	80	10	8	5	3.5	2	25	13	8	5	4	8	4	1.5
80	120	11	10	5	4	2.5	35	18	10	6	5	9	5	2.5
120	150	14	11	6	5	2.5	40	20	11	7	5	10	5	2.5
150	180	19	14	7	5	3.5	45	23	13	8	5	10	5	2.5
180	250	23	15	8	6	4	50	25	15	10	7	11	7	4
250	315	26	19	9	7	4	60	30	18	11	7	13	8	5
315	400	30	21	10	8	5	70	35	20	13	8	13	10	7
400	500	34	25	12	—	—	80	40	23	—	—	15	—	—
500	630	38	29	14	—	—	100	50	25	—	—	18	—	—
630	800	55	34	18	—	—	120	60	30	—	—	20	—	—
800	1000	75	45	—	—	—	140	75	—	—	—	—	—	—
1000	1250	—	—	—	—	—	160	—	—	—	—	—	—	—
1250	1600	—	—	—	—	—	190	—	—	—	—	—	—	—
1600	2000	—	—	—	—	—	220	—	—	—	—	—	—	—
2000	2500	—	—	—	—	—	250	—	—	—	—	—	—	—

Notes: (1) This diameter is included in this group.

(2) Applies before mounting and after removal of internal or external snap ring.

(3) Applies to radial ball bearings such as deep groove ball bearings, angular contact ball bearings.

(4) Outer ring width variation of class 0 and 6 are listed in Table 5.1.1.

(5) Applies to radial ball bearings such as deep groove ball bearing, angular contact ball bearings.

Remarks: The high deviation of bearing cylindrical bore diameter specified in this table does not apply within a distance of  $1.2 \times r$  (max) from the ring face.

**Table 5.1.2 Tolerance Values of Outer Ring****(4/4)**

Bearing outside diameter Nominal D (mm)		Assembled bearing outer ring face runout with raceway $S_{ea}$ (3)			Outer ring width variation $V_{Cs}$ (4)		
		Class 5	Class 4	Class 2	Class 5	Class 4	Class 2
Over	Incl.	Max	Max	Max	Max	Max	Max
2.5 <sup>(1)</sup>	6	8	5	1.5	5	2.5	1.5
6	18	8	5	1.5	5	2.5	1.5
18	30	8	5	2.5	5	2.5	1.5
30	50	8	5	2.5	5	2.5	1.5
50	80	10	5	4	6	3	1.5
80	120	11	6	5	8	4	2.5
120	150	13	7	5	8	5	2.5
150	180	14	8	5	8	5	2.5
180	250	15	10	7	10	7	4
250	315	18	10	7	11	7	5
315	400	20	13	8	13	8	7
400	500	23	—	—	15	—	—
500	630	25	—	—	18	—	—
630	800	30	—	—	20	—	—
800	1000	—	—	—	—	—	—
1000	1250	—	—	—	—	—	—
1250	1600	—	—	—	—	—	—
1600	2000	—	—	—	—	—	—
2000	2500	—	—	—	—	—	—

Notes: (1) This diameter is included in this group.

(2) Applies before mounting and after removal of internal or external snap ring.

(3) Applies to radial ball bearings such as deep groove ball bearings, angular contact ball bearings.

(4) Outer ring width variation of class 0 and 6 are listed in Table 5.1.1.

(5) Applies to radial ball bearings such as deep groove ball bearing, angular contact ball bearings.

Remarks: The high deviation of bearing cylindrical bore diameter specified in this table does not apply within a distance of  $1.2 \times r$  (max) from the ring face.

**Table 5.2.1 Tolerance Values of Inner Ring**

(1/2)

Unit:  $\mu\text{m}$

Bearing bore diameter Nominal d (mm)		Bearing bore diameter											
		Single plane mean bore diameter $\Delta d_{mp}$						Deviation of a single bore diameter $\Delta d_s$		Bore diameter variation in a single radial plane $Vd_p$			
		Class 0 Class 6X		Class 6 Class 5		Class 4		Class 4		Class 0 Class 6X	Class 6	Class 5	Class 4
Over	Incl.	High	Low	High	Low	High	Low	High	Low	Max	Max	Max	Max
10	18	0	-12	0	-7	0	-5	0	-5	12	7	5	4
18	30	0	-12	0	-8	0	-6	0	-6	12	8	6	5
30	50	0	-12	0	-10	0	-8	0	-8	12	10	8	6
50	80	0	-15	0	-12	0	-9	0	-9	15	12	9	7
80	120	0	-20	0	-15	0	-10	0	-10	20	15	11	8
120	180	0	-25	0	-18	0	-13	0	-13	25	18	14	10
180	250	0	-30	0	-22	0	-15	0	-15	30	22	17	11
250	315	0	-35	-	-	-	-	-	-	35	-	-	-
315	400	0	-40	-	-	-	-	-	-	40	-	-	-
400	500	0	-45	-	-	-	-	-	-	-	-	-	-
500	630	0	-50	-	-	-	-	-	-	-	-	-	-
630	800	0	-75	-	-	-	-	-	-	-	-	-	-

Remarks:

1. The high deviation of bearing bore diameter specified in this table does not apply within a distance of  $1.2 \times r$  (max) from the ring face.
2. Some of these tolerances conform with the NACHI Standard.

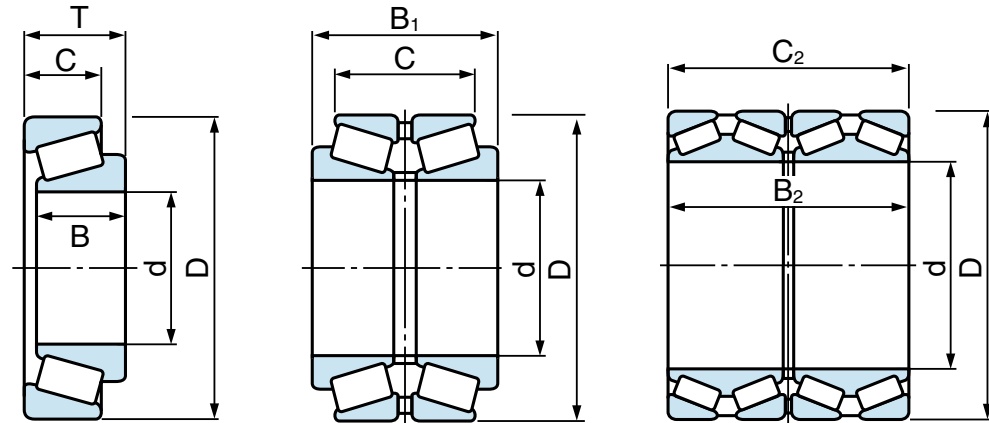

**Table 5.2.1 Tolerance Values of Inner Ring**

(2/2)

Unit:  $\mu\text{m}$

Bearing bore diameter Nominal $d$ (mm)		Bearing bore diameter				Radial runout of assembled bearing inner ring				Inner ring reference face runout with bore		Assembled bearing inner ring face runout with raceway
		Mean bore diameter variation $Vd_{mp}$				Class $K_{ia}$				Class $S_d$		Class $S_{ia}$
		Class 0 Class 6X	Class 6	Class 5	Class 4	Class 0 Class 6X	Class 6	Class 5	Class 4	Class 5	Class 4	Class 4
Over	Incl.	Max	Max	Max	Max	Max	Max	Max	Max	Max	Max	
10	18	9	5	5	4	15	7	5	3	7	3	3
18	30	9	6	5	4	18	8	5	3	8	4	4
30	50	9	8	5	5	20	10	6	4	8	4	4
50	80	11	9	6	5	25	10	7	4	8	5	4
80	120	15	11	8	5	30	13	8	5	9	5	5
120	180	19	14	9	7	35	18	11	6	10	6	7
180	250	23	16	11	8	50	20	13	8	11	7	8
250	315	26	—	—	—	60	—	—	—	—	—	—
315	400	30	—	—	—	70	—	—	—	—	—	—
400	500	—	—	—	—	70	—	—	—	—	—	—
500	630	—	—	—	—	85	—	—	—	—	—	—
630	800	—	—	—	—	100	—	—	—	—	—	—

Remarks:

1. The high deviation of bearing bore diameter specified in this table does not apply within a distance of  $1.2 \times r$  (max) from the ring face.
2. Some of these tolerances conform with the NACHI Standard.

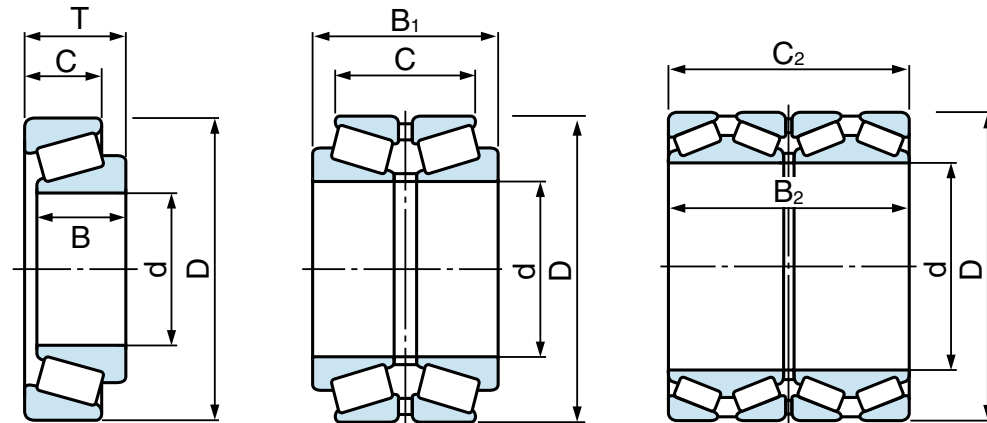

**Table 5.2.2 Tolerance Values of Outer Ring**

(1/2)

Unit:  $\mu\text{m}$

Bearing outside diameter Nominal D (mm)		Bearing outside diameter											
		Single plane mean outside diameter $\Delta D_{mp}$				Deviation of a single outside diameter $\Delta D_s$				Outside diameter variation in a single radial plane $V_{Dp}$			
		Class 0 Class 6X		Class 6 Class 5		Class 4		Class 4		Class 0 Class 6X	Class 6	Class 5	Class 4
Over	Incl.	High	Low	High	Low	High	Low	High	Low	Max	Max	Max	Max
18	30	0	-12	0	-8	0	-6	0	-6	12	8	6	5
30	50	0	-14	0	-9	0	-7	0	-7	14	9	7	5
50	80	0	-16	0	-11	0	-9	0	-9	16	11	8	7
80	120	0	-18	0	-13	0	-10	0	-10	18	13	10	8
120	150	0	-20	0	-15	0	-11	0	-11	20	15	11	8
150	180	0	-25	0	-18	0	-13	0	-13	25	18	14	10
180	250	0	-30	0	-20	0	-15	0	-15	30	20	15	11
250	315	0	-35	0	-25	0	-18	0	-18	35	25	19	14
315	400	0	-40	0	-28	0	-20	0	-20	40	28	22	15
400	500	0	-45	-	-	-	-	-	-	45	-	-	-
500	630	0	-50	-	-	-	-	-	-	50	-	-	-
630	800	0	-75	-	-	-	-	-	-	-	-	-	-
800	1000	0	-100	-	-	-	-	-	-	-	-	-	-

- Remarks: 1. The low deviation of bearing outside diameter specified in this table does not apply within a distance of  $1.2 \times r$  (max) from the ring face.
2. Some of these tolerances conform with the NACHI Standard.

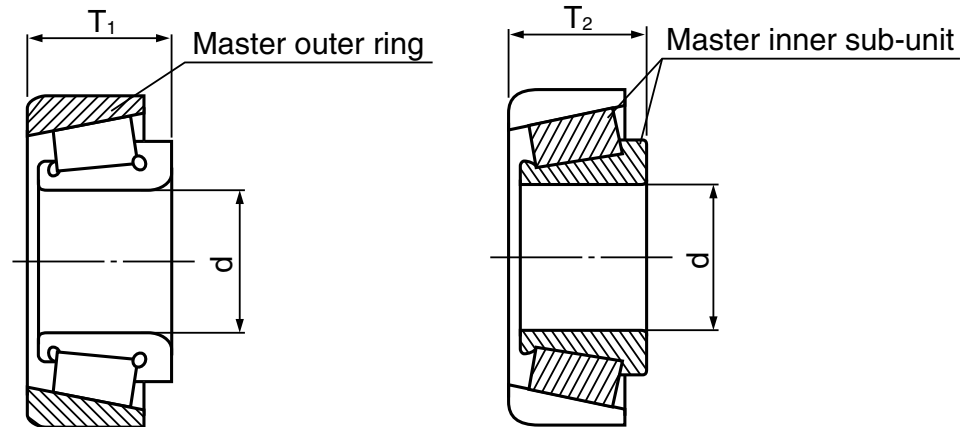

**Table 5.2.2 Tolerance Values of Outer Ring**

(2/2)

Unit:  $\mu\text{m}$



Bearing outside diameter Nominal D (mm)		Bearing outside diameter Mean outside diameter variation $V_{Dmp}$				Radial runout of assembled bearing outer ring $K_{ea}$				Variation of bearing outside surface generatrix inclination with outer ring reference face $S_D$		Assembled bearing outer ring face runout with raceway $S_{ea}$
		Class 0	Class 6	Class 5	Class 4	Class 0	Class 6	Class 5	Class 4	Class 5	Class 4	Class 4
		Class 6X	Class 6	Class 5	Class 4	Class 0	Class 6X	Class 6	Class 5	Class 4	Class 5	Class 4
Over	Incl.	Max	Max	Max	Max	Max	Max	Max	Max	Max	Max	Max
18	30	9	6	5	4	18	9	6	4	8	4	5
30	50	11	7	5	5	20	10	7	5	8	4	5
50	80	12	8	6	5	25	13	8	5	8	4	5
80	120	14	10	7	5	35	18	10	6	9	5	6
120	150	15	11	8	6	40	20	11	7	10	5	7
150	180	19	14	9	7	45	23	13	8	10	5	8
180	250	23	15	10	8	50	25	15	10	11	7	10
250	315	26	19	13	9	60	30	18	11	13	8	10
315	400	30	21	14	10	70	35	20	13	13	10	13
400	500	34	—	—	—	80	—	—	—	—	—	—
500	630	38	—	—	—	100	—	—	—	—	—	—
630	800	—	—	—	—	120	—	—	—	—	—	—
800	1000	—	—	—	—	120	—	—	—	—	—	—

- Remarks: 1. The low deviation of bearing outside diameter specified in this table does not apply within a distance of  $1.2 \times r$  (max) from the ring face.
2. Some of these tolerances conform with the NACHI Standard.

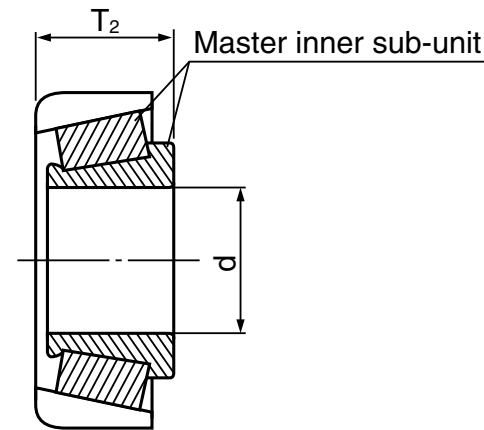
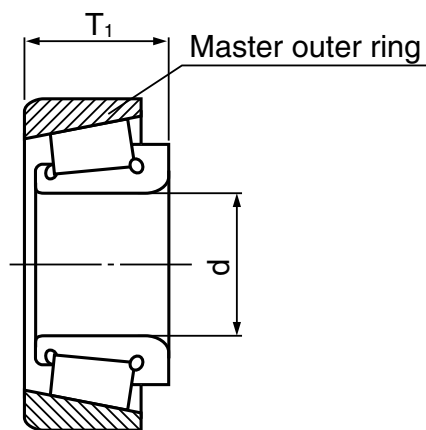

**Table 5.2.3 Deviations of Single Ring Width,  
Bearing Width and Duplex/Stack Mounted Bearing Width**

Unit:  $\mu\text{m}$ 

Bearing bore diameter Nominal d (mm)		Deviation of a single inner ring width $\Delta B_s$						Deviation of a single outer ring width $\Delta C_s$					
		Class 0 Class 6		Class 6X		Class 5 Class 4		Class 0 Class 6		Class 6X		Class 5 Class 4	
		Over	Incl.	High	Low	High	Low	High	Low	High	Low	High	Low
10	18	0	-120	0	-50	0	-200	0	-120	0	-100	0	-200
18	30	0	-120	0	-50	0	-200	0	-120	0	-100	0	-200
30	50	0	-120	0	-50	0	-240	0	-120	0	-100	0	-240
50	80	0	-150	0	-50	0	-300	0	-150	0	-100	0	-300
80	120	0	-200	0	-50	0	-400	0	-200	0	-100	0	-400
120	180	0	-250	0	-50	0	-500	0	-250	0	-100	0	-500
180	250	0	-300	0	-50	0	-600	0	-300	0	-100	0	-600
250	315	0	-350	0	-50	-	-	0	-350	0	-100	-	-
315	400	0	-400	0	-50	-	-	0	-400	0	-100	-	-
400	500	0	-450	-	-	-	-	0	-450	-	-	-	-
500	630	0	-500	-	-	-	-	0	-500	-	-	-	-
630	800	0	-750	-	-	-	-	0	-750	-	-	-	-

Remarks: Effective width of an inner sub-unit  $T_1$  is the bearing width obtained when this sub-unit is mated with a master outer ring.  
Effective width of an outer ring  $T_2$  is the bearing width obtained when this ring is mated with a master inner sub-unit.





**Table 5.2.3 Deviations of Single Ring Width,  
Bearing Width and Duplex/Stack Mounted Bearing Width**

Unit:  $\mu\text{m}$ 

Bearing bore diameter Nominal d (mm)		Deviation of a actual bearing width $\Delta T_s$						Deviation of the actual effective width of inner sub-unit $\Delta T_{1s}$			
		Class 0 Class 6		Class 6X		Class 5 Class 4		Class 0		Class 6X	
Over	Incl.	High	Low	High	Low	High	Low	High	Low	High	Low
10	18	+200	0	+100	0	+200	-200	+100	0	+ 50	0
18	30	+200	0	+100	0	+200	-200	+100	0	+ 50	0
30	50	+200	0	+100	0	+200	-200	+100	0	+ 50	0
50	80	+200	0	+100	0	+200	-200	+100	0	+ 50	0
80	120	+200	-200	+100	0	+200	-200	+100	-100	+ 50	0
120	180	+350	-250	+150	0	+350	-250	+150	-150	+ 50	0
180	250	+350	-250	+150	0	+350	-250	+150	-150	+ 50	0
250	315	+350	-250	+200	0	-	-	+150	-150	+100	0
315	400	+400	-400	+200	0	-	-	+200	-200	+100	0
400	500	+400	-400	-	-	-	-	-	-	-	-
500	630	+500	-500	-	-	-	-	-	-	-	-
630	800	+600	-600	-	-	-	-	-	-	-	-

Remarks: Effective width of an inner sub-unit  $T_1$  is the bearing width obtained when this sub-unit is mated with a master outer ring.  
Effective width of an outer ring  $T_2$  is the bearing width obtained when this ring is mated with a master inner sub-unit.





**Table 5.2.3 Deviations of Single Ring Width,  
Bearing Width and Duplex/Stack Mounted Bearing Width**

Unit:  $\mu\text{m}$

Bearing bore diameter Nominal d (mm)		Deviation of the actual effective width of outer sub-unit $\Delta T_{2s}$				Deviation of duplex/stack mounted bearing width			
		Class 0		Class 6X		$\Delta B_{1s}$ Duplex mounted bearing class 0		$\Delta B_{2s} \bullet \Delta C_{2s}$ Four row bearing class 0	
Over	Incl.	High	Low	High	Low	High	Low	High	Low
10	18	+100	0	+ 50	0	+ 200	- 200	-	-
18	30	+100	0	+ 50	0	+ 200	- 200	-	-
30	50	+100	0	+ 50	0	+ 240	- 240	-	-
50	80	+100	0	+ 50	0	+ 300	- 300	+ 400	- 400
80	120	+100	-100	+ 50	0	+ 400	- 400	+ 500	- 500
120	180	+200	-100	+100	0	+ 500	- 500	+ 600	- 600
180	250	+200	-100	+100	0	+ 600	- 600	+ 750	- 750
250	315	+200	-100	+100	0	+ 700	- 700	+ 900	- 900
315	400	+200	-200	+100	0	+ 800	- 800	+1000	-1000
400	500	-	-	-	-	+ 900	- 900	+1200	-1200
500	630	-	-	-	-	+1000	-1000	+1200	-1200
630	800	-	-	-	-	+1500	-1500	+1500	-1500

Remarks: Effective width of an inner sub-unit  $T_1$  is the bearing width obtained when this sub-unit is mated with a master outer ring.  
Effective width of an outer ring  $T_2$  is the bearing width obtained when this ring is mated with a master inner sub-unit.